

Patient Instructions for Use of VYAFUSER™ Pump

VYAFUSER™ and VYALEV™ are trademarks of AbbVie AB.

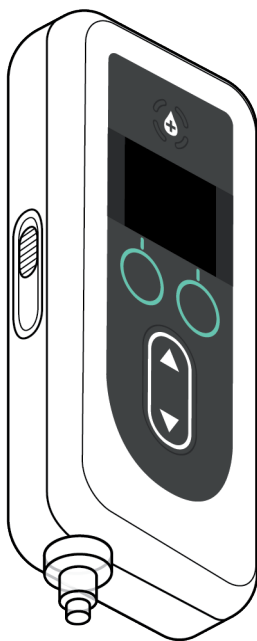

Phillips-Medisize A/S
Gimsinglundvej 20,
DK-7600, Struer,
Denmark

This Patient Instructions for Use of VYAFUSER Pump describes the intended use by Parkinson's patients, their caregivers and healthcare providers for the delivery of VYALEV (foscarnidopa and foslevodopa).

The VYAFUSER pump is an infusion pump that can be carried around (ambulatory). The pump uses single-use syringes for controlled delivery of VYALEV below the skin (subcutaneous). It gives the medicine 24 hours a day, 7 days a week.

Use these instructions along with any other instructions your healthcare provider may give you. Follow only those steps where you have been trained by your healthcare provider. Please read the **Instructions for Use of VYALEV that explains how to prepare the solution** before you start using VYALEV and each time you fill a new syringe.

TABLE OF CONTENTS

1. Introduction	7
1.1 Contraindications, Warnings, and Cautions	7
1.2 General.....	12
1.3 VYALEV and VYAFUSER Pump Intended Use.....	14
1.4 VYALEV Delivery System Overview.....	15
1.5 VYAFUSER Pump Parts	18
1.6 VYAFUSER Pump Display	20
1.7 Delivery Methods.....	23
2. Prepare VYALEV and Infusion Set	25
2.1 Gather Supplies.....	25
2.2 Install the Battery.....	27
2.3 Fill Syringe with VYALEV	30
2.4 Connect the Infusion Set Tubing to the Syringe.....	31
2.5 Place the Filled Syringe in the Pump	32
2.6 Prime Infusion Set Tubing	34
2.7 Insert Cannula into the Body.....	38
2.8 Connect Infusion Set Tubing to Cannula.....	40
3. Administer Therapy	41
3.1 Start Continuous Infusion Delivery	41
3.2 Stop and Resume Therapy	43
3.3 Change the Rate	45
3.4 Administer Extra Dose.....	47
3.5 Stop/Cancel Extra Dose Delivery	49
3.6 Administer Loading Dose	50
3.7 Stop/Cancel Loading Dose.....	52
3.8 Resume Loading Dose.....	53
3.9 Choosing to Not Start Loading Dose.....	54
4. Disconnect and Reconnect From Pump	55
4.1 Disconnect from the Pump (less than 1 hour).....	55
4.2 Disconnect from Site Connector and Remove Drips.....	57
4.3 Reconnect to Pump (within 1 hour).....	58
5. Replace Syringe Only	61
5.1 Gather Supplies.....	62
5.2 Fill Syringe with VYALEV	64

5.3 Stop Therapy.....	65
5.4 Remove Used Syringe from Pump.....	66
5.5 Replace the Syringe.....	67
5.6 Place New Syringe in Pump.....	68
5.7 Resume Continuous Infusion Delivery.....	70
6. Replace Infusion Set Tubing and Cannula (not Syringe)	71
6.1 Gather Supplies.....	71
6.2 Stop Therapy.....	73
6.3 Remove Cannula and Disconnect Infusion Set Tubing from Syringe.....	74
6.4 Connect New Infusion Set Tubing.....	74
6.5 Prime Infusion Set Tubing.....	75
6.6 Insert Cannula and Pad or Needle into the Body.....	78
6.7 Connect Infusion Set Tubing to Cannula and Resume Continuous Infusion Delivery.....	80
7. Replace Syringe, Infusion Set Tubing, and Cannula	81
7.1 Gather Supplies.....	82
7.2 Fill Syringe with VYALEV.....	84
7.3 Stop Therapy.....	84
7.4 Remove Cannula from Infusion Site.....	85
7.5 Remove the Used Syringe from Pump.....	86
7.6 Connect New Infusion Set Tubing to New Syringe.....	88
7.7 Place New Syringe in Pump.....	89
7.8 Prime Infusion Set Tubing.....	90
7.9 Insert Cannula into the Body.....	94
7.10 Connect Infusion Set Tubing to Cannula and Resume Continuous Infusion.....	96
8. Troubleshooting	97
8.1 What do I do if my syringe doesn't fit into the pump?.....	97
8.2 What if I indicate tubing is primed by accident, but I need to continue to prime?.....	97
8.3 What do I do if I need to change only my infusion set tubing and not the cannula?.....	97
8.4 What if I cannot loosen the tubing from syringe when I replace the syringe?.....	98
8.5 What if I am having trouble transferring VYALEV from the vial to the syringe?.....	98
8.6 What if my fully-charged battery lasts less than 24 hours?.....	99
8.7 What if I install a fully-charged battery and the pump doesn't power on?.....	99

8.8	Instructions for cleaning the battery contacts (if needed).	99
8.9	What should I do if the pump screen is blank or does not respond to any of my button pushes?	100
8.10	What should I do if my cannula becomes detached from my body after I have been using it?	100
8.11	What if I cannot remove the site connector from the cannula during temporary disconnect?	100
8.12	What should I do if the system is leaking or if the tubing is blocked?	101
8.13	What should I do if my pump gets wet?	101
8.14	What should I do if I spill VYALEV?	101
8.15	What if I need to stop using the pump for a long period of time?	101
9.	Alarms and Informational Messages	103
9.1	Alarm Overview	103
9.2	High and Low Priority Alarms (listed alphabetically)	105
9.3	Informational Messages	110
10.	Device Information	115
10.1	Last 3 Alarms	115
10.2	Software Version	116
11.	Maintenance	117
11.1	Replace Battery	117
11.2	Cleaning the Pump, Mains Adapter and Charger	120
12.	Storage and Transport Conditions	121
13.	Technical Specifications	123
13.1	Technical Features	123
13.2	Battery Service Life	129
13.3	MRI Safety Information	129
13.4	Electromagnetic Compatibility	129
14.	Reference	135
14.1	Explanation of Symbols	135
14.2	Pump Kit Labels	137
14.3	Tubing, Adapters, and Accessories	138

GLOSSARY

	Definition
Continuous Infusion Delivery	A delivery of VYALEV that runs throughout the day and night. The base rate is always available. A low and/or high rate may also be delivered if enabled by your healthcare provider.
Extra Dose	A small, single-volume dose given over a short period of time (bolus). The extra dose is only available if it is enabled by your healthcare provider.
Loading Dose	A large single dose given over a short period of time (bolus). The loading dose may be delivered at the start of therapy. It may also be delivered after the pump has not been giving VYALEV for a long period of time (minimum of 3 hours).
Lockout Time	The duration of time during which an extra dose or loading dose cannot be delivered. These times are set by the healthcare provider.
Lockout Time: Extra Dose	This lockout time is the time the extra dose is not available.
Lockout Time: Loading Dose	This lockout time is the time the loading dose is not available. During this time, the loading dose option will not be visible on the pump display.
Solution	Liquid formulation in a glass medicine vial that is prescribed by the healthcare provider.

1. Introduction

1.1 Contraindications, Warnings, and Cautions

Contraindications, Warnings, and Cautions notify you of potential hazards.

A contraindication is when a device should not be used because the risk of use is more than any benefit you could get.

Warning statements notify you of potential hazards that may cause serious harm or death. All warnings are written with the following symbol to the left of the warning. 

Caution statements notify you of potential hazards that may cause moderate harm or damage to equipment.







You should read and understand them prior to using this delivery system.

Contraindication

 VYALEV (see Instructions for Use for VYALEV) and the delivery system, as described in this Instructions for Use, should only be used as prescribed to you by your healthcare provider.

Warnings





General

-  Only use the pump in a manner described in this Instructions for Use, or as you were trained by your healthcare provider.
-  **Do not** interact with the pump, including adjusting the dosage and/or addressing any alarms or informational messages, while operating motorized vehicles or machinery, or otherwise engaging in any activities where distractions need to be avoided.
-  Keep the pump, especially the battery and all other small parts, out of the reach of children. A small part may be a choking hazard for children.
-  **Do not** try to change any part of the delivery system. If you do, you could damage the system, harm yourself, or cause your therapy to be less effective.
-  **Do not** dilute the VYALEV solution or fill the syringe with anything other than what your healthcare provider prescribed.
-  Only use the carrying accessory that comes with the VYAFUSER pump.

-  **Do not** store the pump, battery, or battery charging parts outside of the temperature range -4 °F to 140 °F (-20 °C to 60 °C).



Battery (RRC1120-PM)

To reduce the risk of damage to the battery or pump or to harm yourself:

-  **Do not** use a battery that is different from the Model RRC1120-PM battery provided by the VYAFUSER pump supplier.
-  **Do not** open or take apart batteries.
-  **Do not** expose batteries to direct source of heat.
-  **Do not** use batteries with any physical damage that you can see like cracks, broken parts, etc.







Battery Charging Station Parts (AC/Mains Adapter and Battery Charger)





To reduce the risk of electric shock or other harm to you:

-  **Do not** use the battery charging parts if they look damaged.
-  **Do not** use battery charging parts that are different from the AC/Mains adapter and battery charger provided by the VYAFUSER pump supplier.

Disposable Parts (Vial Adapter, Syringe, Infusion Set)





To reduce the risk of infection or allergic reactions:

-  **Do not** use any disposable parts that have not been qualified for use with this system. This includes the vial adapter, infusion set, and syringe. The list of qualified disposable parts can be found at devices.abbvie.com.
-  **Do not** use any disposable parts, including the infusion set and vial adapter, until you have read the Instructions for Use and have understood and will follow all warnings and cautions.
-  **Do not** use any disposable parts past the expiration date on the label.
-  **Do not** use any disposable parts if their sterile packaging has been damaged prior to use.
-  **Do not** re-use any disposable part, such as the syringe or vial adapter.
-  **Do not** use an infusion set for a time period longer than noted in the Instructions for Use or instructed by your healthcare provider.

-  Always throw away (dispose of) the used infusion set per local regulations.
-  **Do not** attempt to move the cannula after it has been installed on the infusion site. If the cannula needs to be re-adjusted, change to a new infusion set and a new infusion site.
-  To reduce the risk of infections when using disposable parts (vial adapter, syringe, and infusion set), always follow how your healthcare provider tells you to use them. **Do not** let the tip of any disposable part contact any unclean surfaces. If the tip of any disposable part contacts an unclean surface, discard it and get a new one.
-  Once you have opened a disposable part packaging, it should be used or discarded. Do not save it for later use.
-  **Do not** touch your infusion site area once it has been cleaned.

System Use Conditions

To reduce the risk of pump malfunction and harm to yourself:

-  **Do not** use or wear the pump while doing any activity that could cause liquids to get onto or into the pump. Some of these activities include taking a bath or shower, or swimming.
-  **Do not** use the pump if it has been put in water or any other liquid. Contact your healthcare provider for help in getting the pump replaced.
-  Keep the pump at least 3.1 inches (8 cm) away from portable radio frequency (RF) communications equipment (e.g., cell phones, laptops, tablets, Wi-Fi routers, cordless phones, including peripherals such as antenna cables and external antennas). Otherwise, this pump may not work as well as it should.
-  Always keep the VYAFUSER pump away from conditions or environments that may affect the pump. Examples include:
 - any direct source of heat (e.g., radiator, stove, sauna)
 - high moisture (greater than 90% relative humidity) (e.g., steam room)
 - contact with or directly next to other electrical equipment (e.g., do not keep the VYAFUSER pump on or directly next to other electrical equipment, such as a laptop or clock radio, or place other electrical equipment on the VYAFUSER pump).

- strong electromagnetic fields (e.g., magnets, MRI devices, loudspeakers)
- ionizing radiation (e.g., X-ray)
- ultrasound devices
- oxygen-rich environments (e.g., surgical rooms)
- environments containing medicine that can catch on fire (e.g., a room where gas medicine to make a patient sleep during surgery is used)
- hyperbaric chambers (e.g., pressure chamber where the working pressure is higher than the air pressure at sea level)

 Your pump contains magnets, which might interfere (e.g., alter device function, turn device on/off) with the use of other electronic medical devices (e.g., deep brain stimulator, pacemaker, cardio-defibrillator, hearing aid).

 If you have an implanted heart (cardiac) device (e.g., pacemaker and/ or cardioverter-defibrillator), keep the VYAFUSER pump at least 6 inches (150 mm) from the heart device. Consult the instructions for your heart device and consult your healthcare provider for more information.

Note: Your pump has a magnetic flux density of less than 10 gauss at a distance of 1 inch (25 mm) from any surface when in use.

Cautions

General

If the following cautions are not followed, then the system may not work as it is supposed to:

- Use the delivery system only for subcutaneous (under the skin) delivery of VYALEV (foscarnodopa and foslevodopa).
- **Do not** use the pump outside the recommended operating temperature range of 41 °F to 104 °F (5 °C to 40 °C).
- **Do not** heat any part of the delivery system in any type of oven, including a microwave oven.
- If the pump is dropped, inspect it for damage. If any damage is detected, do not use it and call your healthcare provider immediately.
- When the VYAFUSER pump displays an alarm or informational message you must perform the corrective actions as described in this Instructions for Use, if applicable.

- **Do not** use the infusion set tubing, carrying accessory straps or belt, or battery charging station cable in a way that could wrap around your neck.
- **Do not** place your fingers or hand in a position that could result in it getting pinched, such as when closing the pump lid or battery cover.
- If you think the skin around your infusion site is irritated, call your healthcare provider.

Preparing VYALEV for Use

If the following cautions are not followed, then the therapy may not be effective or safe.

- **Do not** store the unopened VYALEV solution vials outside the recommended storage conditions specified in the Instructions for Use of VYALEV, which is included with the solution vial carton.
- **Do not** use an unopened solution vial if it has been out of the recommended refrigerated temperature range for longer than the number of days specified in the Instructions for Use of VYALEV, which is included with the solution vial carton.
- **Do not** use the VYALEV solution if it has been in the syringe for more than 24 hours.
- **Do not** use the VYALEV solution if it is cloudy or contains flakes or particles.
- **Do not** freeze the VYALEV solution.
- **Do not** infuse hot fluids.
- If refrigerated, **do not** warm VYALEV (in solution vial or syringe). Let VYALEV warm to room temperature. For example, do not warm in a microwave or in hot water.
- Always withdraw the entire contents of the solution vial into the syringe. **Do not** save VYALEV solution in the vial for later use.

Disposable Parts (Vial Adapter, Syringe, Infusion Set)

- Inspect all disposable parts before use. **Do not** use any of the parts if they are damaged. Use of damaged parts may not be safe.
- Always insert the cannula as indicated in the infusion set Instructions for Use. Care for your infusion site as directed by your healthcare provider or you could risk infection of the infusion site.
- **Do not** prime the infusion set tubing when connected to the body. Priming the tubing while connected to the body may result in unintended drug delivery.

- Always visually inspect the infusion site for bleeding right after you insert the cannula. If you see blood in the tubing and/or near the infusion site, replace the infusion set (both cannula and tubing) and choose a new infusion site.
- Always look to confirm that the cannula is completely removed from your body when you remove the cannula adhesive. If you think the plastic part of the cannula was detached from the adhesive and is still under your skin, call your healthcare provider.

Battery

If the following cautions are not followed, it may lead to battery fluid leaks and may not be safe.

- Always remove the battery if the pump will not be used for a period of 1 month or longer.
- Recycle/dispose of batteries according to national and local regulations.
- In the event of a battery leaking, **do not** allow the battery liquid to come in contact with the skin or eyes. If battery liquid contact has been made, wash the affected area with plenty of water and call your healthcare provider.

1.2 General

- Do not use VYALEV that has been in a syringe for more than 24 hours. After 24 hours, throw away (discard) the syringe with any unused VYALEV and replace it with a new syringe of fresh VYALEV.
- For delivery periods of 6 hours or more, the average flow rate will be within $\pm 10\%$ of the programmed rate across the entire programmable range. For delivery periods of 1 hour, the average flow rate may differ from the programmed rate by up to ± 0.1 mL/hr for flow rates from 0.15 to 0.70 mL/hr.
- When the syringe is in the pump and the infusion set tubing is connected to the body, the syringe should be within 7 3/4 inches (20 cm) above and 21 1/2 inches (55 cm) below the infusion site. Placing it higher or lower than this could impact delivery accuracy.
- In the presence of abnormally high back pressure (e.g., from a partial blockage or closure) the average flow rate may be reduced for the first 30-60 minutes. The flow rate will return to normal after this time.
- System delivery inaccuracy may result in under- or over-delivery of medication. Inaccuracies beyond $\pm 10\%$ due to fluid back pressure may occur from:

- Placing the infusion set on yourself (or the patient) in a manner inconsistent with this labeling
 - Placing the pump above or below the infusion site in a manner inconsistent with this labeling
 - Delivering a fluid other than VYALEV (foscarnidopa and foslevodopa)
 - Using disposable parts other than those named for and qualified for use with this system
 - Using at operating temperatures, humidities, and atmospheric pressures outside of the designated operating ranges
- The pump is made to operate as it is supposed to when it operates within the correct temperature, humidity, and atmospheric pressure ranges. The temperature range should be from 41 °F to 104 °F (5 °C to 40 °C). The humidity range should be between 15% to 90% non-condensing, inclusive. The atmospheric pressure range should be from 70 kPa to 106 kPa.
 - The pump is made to operate in the electromagnetic environment specified in the section ***Technical Specifications: Electromagnetic Compatibility***.
 - Talk with your healthcare provider about what to do in case you are unable to use VYALEV infusion. Keep a supply of backup oral Parkinson's disease medicines with you at all times.

Expected Service Life

- The expected service life of the pump is 3 years.

1.3 VYALEV and VYAFUSER Pump Intended Use

This Instructions for Use provides information for the VYAFUSER pump (see *Figure A*). Use these instructions along with any other instructions your healthcare provider may give you. Follow only those steps where you have been trained by your healthcare provider. Please read the **Instructions for Use of VYALEV** before using VYALEV and filling a new syringe.

The VYAFUSER pump is an infusion pump that you can walk around with. The pump uses single-use syringes for the controlled subcutaneous administration of VYALEV. It provides continuous infusion 24 hours a day, 7 days a week. The continuous infusion does not always sound like it is infusing because it delivers medicine for about 2 seconds and then rests for period to achieve the set flow rate. The pump can be used in the home, outside the home, and during travel (including air travel).

When delivering VYALEV, the pump can be placed in any orientation (horizontally or vertically).

Your healthcare provider prescribed VYALEV for you and set up the VYAFUSER pump. For questions or problems, please contact your healthcare provider.

The VYAFUSER pump is used for the delivery of VYALEV (foscarbidopa and foslevodopa) through subcutaneous infusion.

Note: Do not attempt to take apart the pump.

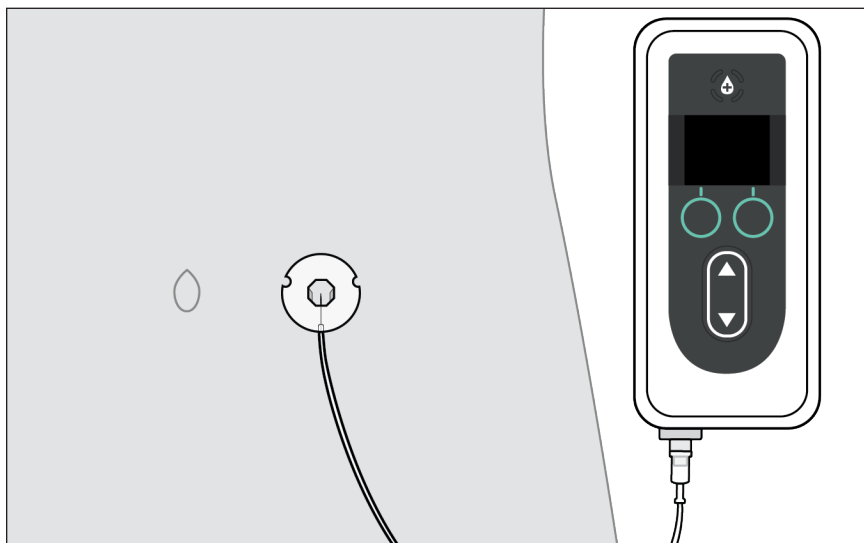





Figure A





1.4 VYALEV Delivery System Overview



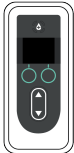

The delivery system refers to the pump, the solution vial, and all of the items shown in the following table.

Note: When you get your new pump, the battery may not be fully charged. Charge your spare battery right away. When it is fully charged, replace the pump battery with the newly charged battery and begin to charge the one you replaced (see section **Maintenance: Replace Battery**).

Note: The cannula and infusion set tubing must be changed at regular periods, as per the instructions from your healthcare provider.

Item	Purpose	Instructions for Use (IFU)
Solution Vial 	The solution vial contains VYALEV.	Vial Adapter VYALEV
Vial Adapter 	The vial adapter is attached to the solution vial and is used to transfer VYALEV from the solution vial to the syringe. Your vial adapter may look different from the one shown here.	Vial Adapter VYALEV
Syringe 	The syringe is to be filled with VYALEV and is then used in the pump to deliver VYALEV.	VYALEV VYAFUSER Pump for Patients Infusion Set

Item	Purpose	Instructions for Use (IFU)
<p>Pump</p> 	<p>The infusion pump delivers VYALEV from the syringe through the infusion set tubing and into the infusion site.</p> <p>VYAFUSER pump: model number and serial number are found when the pump lid is open.</p>	<p>VYAFUSER Pump for Patients</p> <p>VYAFUSER Pump Carrying Accessory</p>
<p>Infusion Set Tubing (Infusion Line)</p> 	<p>The infusion set tubing connects the syringe in the pump to the infusion site to deliver VYALEV.</p> <p>Your infusion set tubing may look different from the one shown here. It may also be called an infusion line.</p>	<p>VYALEV Infusion Set</p>
<p>Insertion Device and Cannula</p>  <p>Insertion Device</p>  <p>Cannula</p>	<p>The insertion device is used to insert the cannula into the body. It may do this through a mechanical method or manual method, depending on your insertion device.</p> <p>When the cannula is inserted into the infusion site, it allows VYALEV to flow into your body.</p> <p>Your insertion device and cannula may look different from the ones shown here.</p>	<p>VYALEV Infusion Set</p>

Item	Purpose	Instructions for Use (IFU)
<p>Battery</p> 	<p>The rechargeable battery is used as the power source for operating the pump. It must be the Model RRC1120-PM battery.</p>	
<p>AC/Mains Adapter</p> 	<p>The battery charger and AC/Mains adapter are used to charge one battery while the other is in use. This will ensure the pump will always have enough power to operate.</p>	<p>AC/Mains Adapter (Instruction Manual Power Supplies)</p>
<p>Battery Charger</p> 	<p>Note: The AC/Mains adapter IFU contains safety information. You should read it to learn about the warnings for the adapter and how to use the adapter. The IFU also shows an adapter that needs to be put together. Your AC/ Mains adapter is already put together.</p> <p>If it comes apart, refer to the AC/Mains adapter IFU as needed.</p>	<p>Battery Charger (RRC SCC1120-PM Series)</p>
<p>Carrying Accessory</p> 	<p>The carrying accessory is used to carry the pump on your body when you are mobile.</p> <p>The carrying accessory contains a carrying case, belt, strap, and removable front flap.</p>	<p>VYAFUSER Pump Carrying Accessory</p>

1.5 VYAFUSER Pump Parts

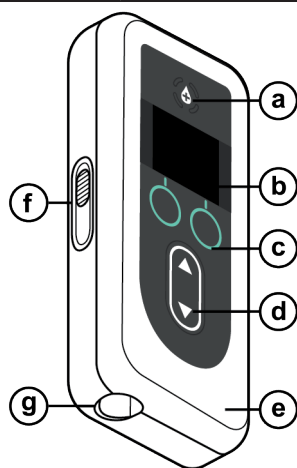

a.	Extra Dose Button	Used to deliver extra doses of VYALEV, if your healthcare provider allows.
b.	Display	Contains pump status information and options for user actions.
c.	Selection Buttons	Used to select between different choices on the display.
d.	Arrow Keys	Up arrow: Used to scroll through menu options or increase a value. Down arrow: Used to scroll through menu options or decrease a value.
e.	Lid	The pump is a clamshell that opens for inserting and removing the syringe. The lid is the part of the clamshell with the display, buttons, and arrow keys.
f.	Lid Latch	The lid latch can be slid to release the lid closing lock.
g.	Syringe Opening	The part of the syringe that connects to the tubing sticks out through this opening.

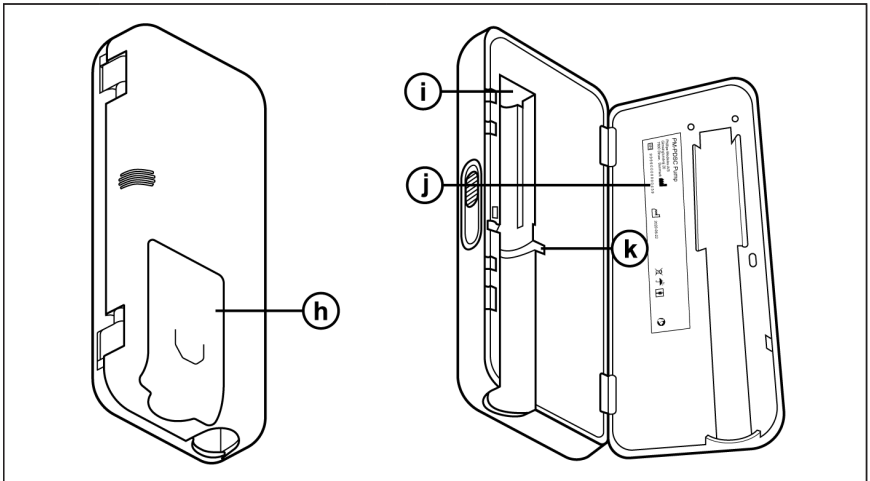

h.	Battery Cover	Slides into place to close the battery compartment.
i.	Syringe Plunger Rod Pusher	Pump mechanism that pushes against the syringe plunger rod to control the flow of VYALEV.
j.	Pump Information	Includes model and serial number.
k.	Syringe Flange Grooves	Houses the syringe flanges and ensures proper alignment of the syringe when inserted into the pump.

If you need help in setting up the system, using, or maintaining the system, or are missing any parts, contact your healthcare provider.

If you need to report any unexpected operation or events, contact your healthcare provider.





If you need to replace your pump and/or dispose of it, contact your healthcare provider.

1.6 VYAFUSER Pump Display

Note: If needed, insert a battery into the pump (see section **Maintenance: Replace Battery**).

Battery Charge

The battery icon indicates different charge levels. The levels go from 4 white bars down through 3, 2, and 1 white bar, then to 1 yellow bar, and finally to a red outline with no bars.

Battery Icon	Meaning
	Four white bars: fully charged
	One white bar: make sure replacement battery is available
	Yellow outline and one yellow bar: battery could be used up within 4 hours
	Red outline and no bars: battery could be used up within 30 minutes. Replace right away.



Pump Status Screen

Used to show pump status.



Note: For other screens that are not the status screen, the top right corner will display only a green circle (for pump running) or red square (for pump stopped).



Replace syringe in

Shows the hours and minutes left until the syringe will be empty, or how many hours and minutes are left until the VYALEV in the syringe should be discarded and replaced with a new syringe.

Note: The number representing hours and minutes may change when the rate is changed.



Current Rate

Displays the rate that is being pumped in milliliters per hour (mL/h).

SCREEN OFF**Display On/Off**

Pressing the left selection button turns the pump display off. Turning off the pump display helps to save battery power.

Note: This will not turn the pump on or off, it will only turn off the display.

Note: If SCREEN OFF is not pressed, the pump display will turn off after 20 seconds of inactivity.

To turn the screen on, press either arrow key or selection button.

**High priority alarm with audible tones (red)**

Many high priority alarms cause the pump to stop. Take action to resolve.

**Low priority alarm with audible tones (yellow)**

Pump is running. If action is not taken as indicated in the alarm message, it may lead to high priority alarm.

**Alarm acknowledged but not resolved**

Audible tones are silenced by pressing any button.

**Informational message with audible tones**

Provides status information.

**Extra Dose**

Indicates the physical extra dose button.

**Up**

Indicates when there are additional menu options above the top displayed item.

**Down**

Indicates when there are additional menu options below the bottom displayed item.

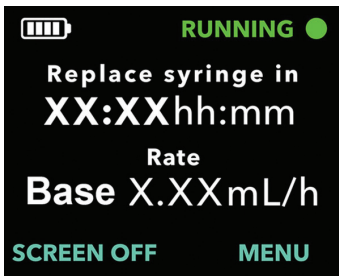

Screen Status

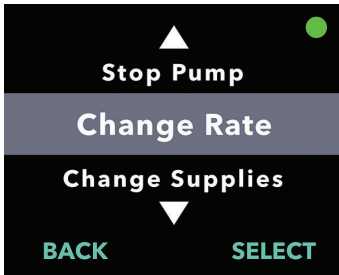

Pump Menus

Pressing the MENU button will display the pump menu options. When menu options are displayed, the SELECT button will choose the highlighted menu option. The pump menus are used to make changes in therapy and supplies.

MENU

Pressing the right MENU button will display additional menu options.

BACK

Back

Goes back to the status screen.

SELECT

Select

Selects the highlighted menu selection option. The highlighted option is changed by pressing the arrow keys.

1.7 Delivery Methods

The pump delivers VYALEV in 3 ways:

	Purpose	When it is available	How to access it
Continuous Infusion	Main mode that delivers a continuous dose of VYALEV throughout the day.	Always available, as prescribed.	Select MENU and then the option to “Start Pump” and follow the prompts (see section Start Continuous Infusion Delivery).
Extra Dose	A small, single-volume dose given over a short period of time (bolus). The extra dose is only available if it is enabled by your healthcare provider.	Available as needed, defined by a pre-set extra dose lockout time.	While the pump is running, press the extra dose button two times (see section Administer Extra Dose).
Loading Dose	A large single dose given over a short period of time (bolus) that may be delivered, only available after the pump has been off for an extended period and it is enabled by your healthcare provider.	After therapy has not been delivered for a long period of time, defined by the loading dose lockout time (minimum of 3 hours).	Select MENU and then the option to Start Loading Dose (see section Administer Loading Dose) <i>Note:</i> The loading dose option is only available when the pump has been off for a long time. It is only accessible after “Start Pump” is selected. You cannot select it from the main display MENU option.

THIS PAGE IS INTENTIONALLY LEFT BLANK.

2. Prepare VYALEV and Infusion Set



Please refer to the **Instructions for Use of VYALEV** and the **Infusion Set Instructions for Use**.

Instructions for Use of VYALEV and Infusion Set

2.1 Gather Supplies

1. Select a clean, flat workspace.
2. As needed, open the pump kit and remove all items.
3. Gather supplies, including (see **Figure B**):

- Pump
- Syringe
- New, unused paper towels
- Insertion device*
- Solution Vial
- Vial adapter*
- Alcohol pads
- Infusion set*

Note: Always make sure that you have replacements for all of your disposal parts.

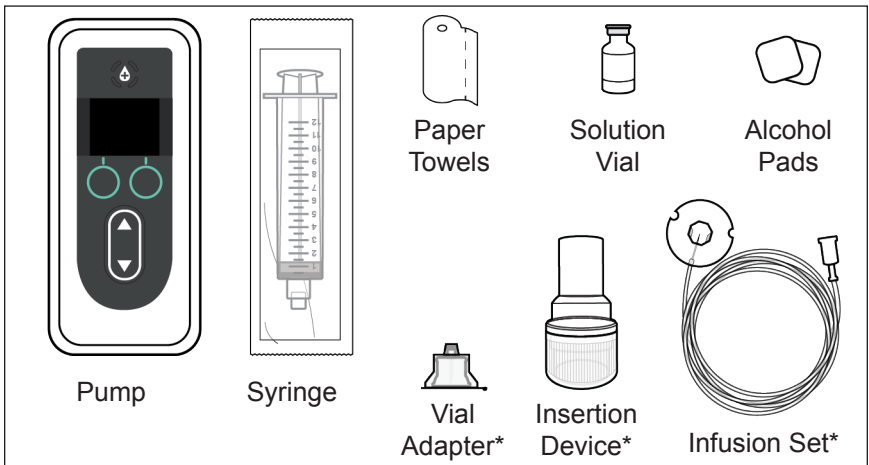

Figure B

*Your insertion device, infusion set, and vial adapter may look different from the ones shown in **Figure B**.

Note: If refrigerated, make sure you warm the solution vial at room temperature for 30 minutes before you fill the syringe.

4. Inspect parts for expiration and for any packaging damage.

- a. Inspect and verify that all parts have not expired and that there is no damage to any of the packaging. If any of the parts have expired or if the packaging is damaged, **do not** use. Contact your healthcare provider.
- b. Inspect the contents of the solution vial. Verify that you **do not** see cloudiness or particles in the liquid.

Note: The packaging for the infusion set, vial adapter and syringe state that they are sterile. The packaging also states how they were sterilized.

Warning: Verify that the solution is VYALEV as prescribed by your healthcare provider.

Warning: Check expiration date for all disposable parts. **Do not** use a part if it is expired.

Warning: **Do not** use any disposable parts if their sterile packaging has been damaged before use.

Caution: Inspect all disposable parts before use and **do not** use any of them if they are damaged.

Caution: **Do not** use VYALEV if it has been in the syringe for more than 24 hours.

Caution: **Do not** use VYALEV if it is cloudy or contains flakes or particles.



Figure C

5. Wash your hands with soap and water and dry them (see Figure C).

2.2 Install the Battery

Note: Always charge the used battery right away after you remove it from the pump. This will make sure that you have a fully charged spare battery available at all times. Only use a fully charged battery, Model RRC1120-PM.

1. **Remove the pump and one battery from the package.**
 - a. Inspect the pump and battery to make sure there is no damage.
2. **Set up the charging system.**
 - a. Remove the AC/Mains adapter, charging station cable, and battery charger from the pump kit.
 - b. Connect the charging station cable to both the AC/Mains adapter and battery charger.
 - c. Plug the AC/Mains adapter into a wall outlet.
 - d. Make sure the red indicator is lit.
 - e. When the red indicator is lit, the battery charger is ready to charge the battery.
3. **Put the battery that is not charged into the battery charger to start charging it.**



Please refer to the ***AC/Mains Adapter Instructions For Use*** and ***Battery Charger Instructions For Use***.

AC/Mains Adapter and Battery Charger

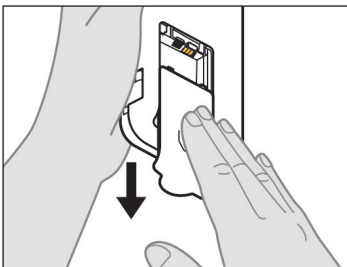

Figure D

4. **Remove the battery cover from the pump (see *Figure D*).**

Note: Always charge batteries fully before storing. If you do not, this could affect how the battery and the charger work.

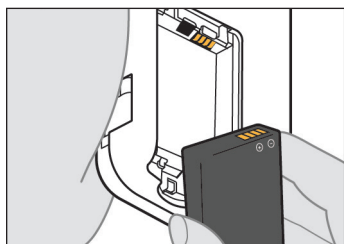

Figure E

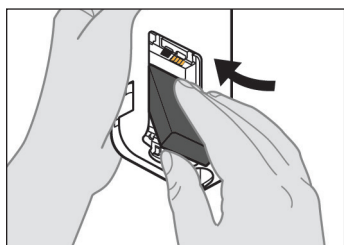

Figure F

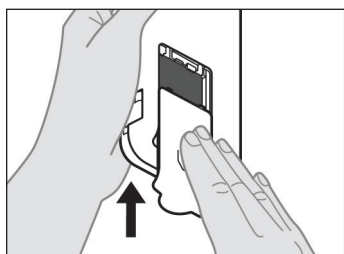

Figure G

5. Put the battery into the battery compartment.

Note: Use only a fully charged battery, Model RRC1120-PM, provided by the VYAFUSER pump supplier.

- a. Match the metal contacts of the battery and battery compartment (see *Figure E*).
- b. Put the metal contact end in first, then slide the battery into the compartment (see *Figure F*).

Note: You will hear a “click” when the battery is in place.

6. Slide the battery cover onto the pump (see *Figure G*).

- a. Once the battery is put in, the display will turn on.

Note: Always make sure the battery cover is fully closed before use.

7. Put the used battery into the battery charger to start charging it.



**Preparing for use.
Please wait...**



Please wait.



STOPPED

Replace syringe in
XX:XX hh:mm

Rate
Base X.XX mL/h

SCREEN OFF **MENU**

8. After putting in the new battery, the pump will run power on self-tests.
9. After putting in the battery, wash your hands with soap and water and dry them.
10. When the self-tests are completed, the pump will display the status screen.

2.3 Fill the Syringe with VYALEV

1. Find a well-lit area and a flat surface like a table.

Note: To reduce the risk of infection, make sure your work surface is clean.

 **Warning: Do not** let the tip of any disposable parts come into contact with any surfaces that are not clean. This will help to reduce the risk of infections. If the tip of the vial adapter or syringe comes into contact with a surface that is not clean, throw it away and get a new one.



***Instructions for Use
of VYALEV***

2. Fill the syringe with VYALEV.

Please refer to your ***Instructions for Use of VYALEV*** for detailed steps on how to:

- Connect the vial adapter to the solution vial
- Transfer VYALEV from the solution vial to the syringe
- Remove air bubbles
- Remove all air from the syringe

2.4 Connect the Infusion Set Tubing to the Syringe



Infusion Set

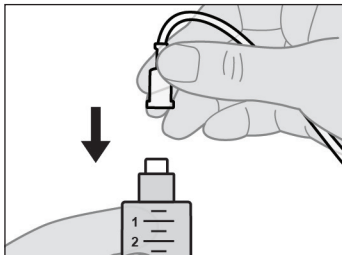

Figure H

1. Remove the infusion set tubing from the package.

Please refer to your **Infusion Set Instructions For Use** for detailed steps.

2. Attach the infusion set tubing to the new syringe (see *Figure H*).

Note: You must change the cannula and infusion set tubing regularly. Your healthcare provider will tell you how often to do this.

Warning: Do not let the tip of any disposable part come into contact with any surface that is not clean. This will help to reduce the risk of infections. If a tip of the infusion set tubing or syringe comes into contact with any surface that is not clean, throw it away and get a new one.

2.5 Place the Filled Syringe in the Pump

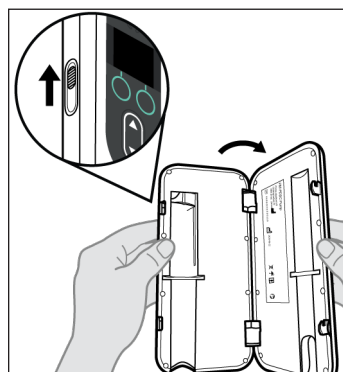
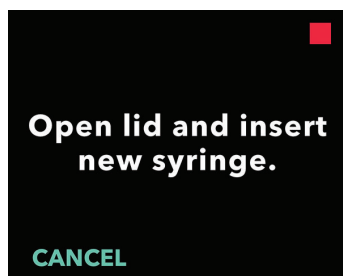
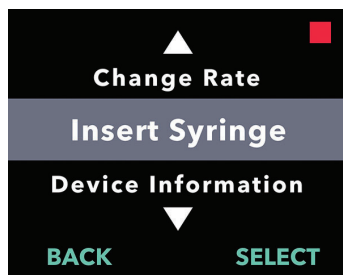
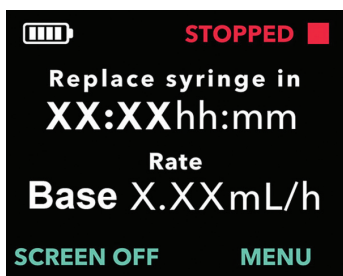

Figure 1

1. Turn on the pump display.
 - a. Press any button (arrow keys or selection buttons).
 - b. Press MENU to display the pump menu options.

2. Use the arrow keys to highlight the Insert Syringe menu option.
 - a. Press SELECT to choose the option to *Insert Syringe* and then follow the instructions on the display.

Note: If the pump does not detect a syringe, it will show the *Insert Syringe* menu option.

3. Slide the lid latch to release the lock and open the pump lid (see Figure 1).

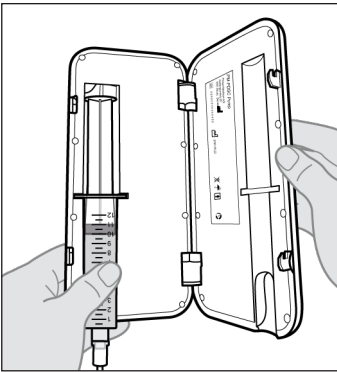

Figure J

**Insert new syringe.
Close lid.**

**Is new syringe
inserted?**

NO

YES

**Preparing for use.
Please wait...**



4. Place the syringe into the pump.

- a. Place the syringe into the pump groove with the syringe flanges in the syringe flange grooves (see *Figure J*).

Note: The syringe should fit into the pump groove with little to no resistance. If the syringe does not fit in the pump groove, check to see if the syringe plunger has moved to the right place and air has been removed.

Note: Make sure the syringe is correctly seated in the pump before closing the pump lid.

If there is still air in the syringe tip, the syringe may not fit into the pump. If this happens, make sure the tubing is not connected to the cannula. Then carefully push out the rest of the air. Be careful not to also push out any of the VYALEV.

- b. Close the pump lid until it snaps shut and the syringe is secured in place.

5. Confirm the new syringe has been inserted.

- a. Press YES.
- b. Pause to allow the pump to prepare the new syringe for use.

2.6 Prime Infusion Set Tubing

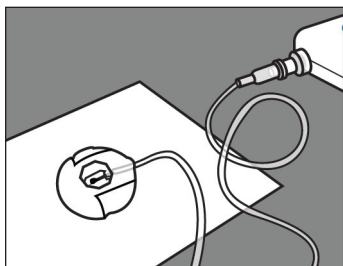
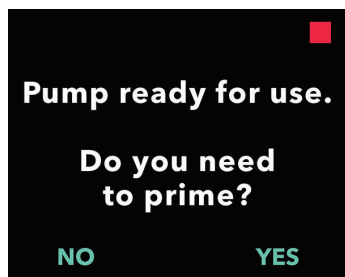

Figure K

1. Prepare to prime the infusion set.

- a. Lay the needle end of the infusion set on a clean paper towel. This is so that the drops will fall on the paper towel and will not fall onto any part of the connector (see *Figure K*).

Note: Your infusion set may look different from the one shown here.



2. Start the priming process.

- a. Press YES.

Note: You may need to stabilize the tubing by holding it with your finger.

Note: If the tubing is new, you need to prime it.

Note: Pressing NO will return you to the status screen.

Note: If you need to prime and do not see this screen, from the status screen select "MENU". Scroll to and select "Change Supplies", and then scroll to and select "Prime Infusion Line."

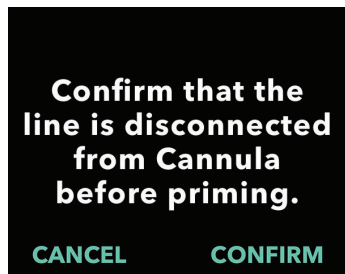

3. Confirm the infusion line is NOT connected to the Cannula.

- a. Press CONFIRM.

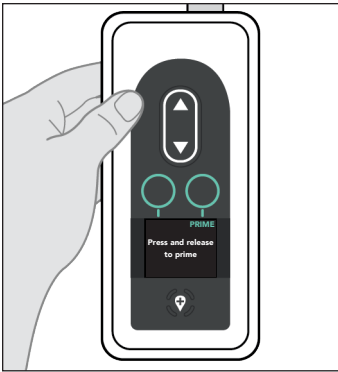

Figure L

**Hold pump
with syringe tip
straight up**



**Press and release
to prime**

PRIME

4. Prime the infusion set.

- a. Hold the pump with the syringe tip straight up (see *Figure L*).

Note: The display will rotate so that you can read it when the pump is held this way for priming.

- b. Press PRIME.

Note: The pump must be pointing straight up and not tilted or the option PRIME will not appear. Make sure the pump is not tilted.

Note: If the pump is tilted slightly, the display will tell you that the syringe tip must point straight up to be able to prime.

Note: Each time you press PRIME, the pump will put a volume of solution into the infusion set and stop.

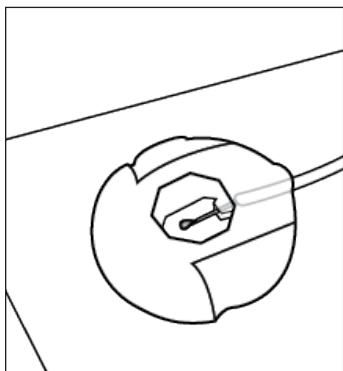

Figure M

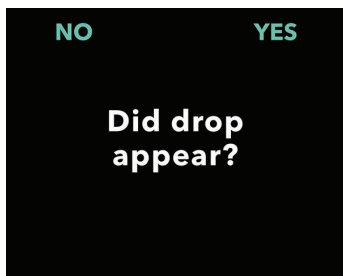
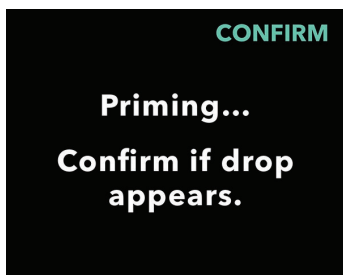

Figure N

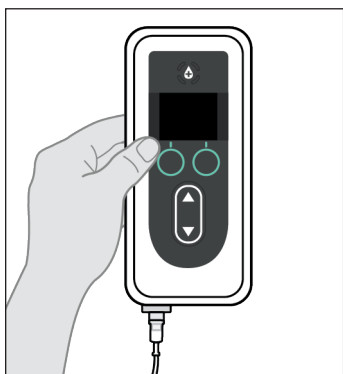

Figure O

5. Look for a drop of VYALEV on the site connector needle (see *Figure M*).

- a. Press CONFIRM when you see a drop of VYALEV on the site connector needle.
- b. Press YES to confirm the appearance of the drop.

Note: It may take several seconds for the drop to appear.

Note: If CONFIRM is not pressed, you will be asked if a drop appeared (see *Figure N*).

Note: Pressing NO will bring you to the previous screen. This will allow you to continue priming the pump until a drop appears.

6. Return the pump to its original position (see *Figure O*). Place the pump flat on the table.

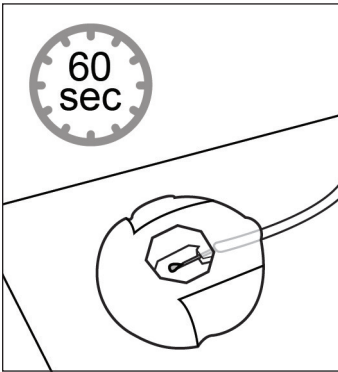

Figure P

7. **Wait at least 60 seconds to ensure that the VYALEV has stopped dripping from the needle (see Figure P).**

Note: You **MUST** wait at least 60 seconds for the dripping to stop

Note: You may need to stabilize the tubing by holding it with your finger.

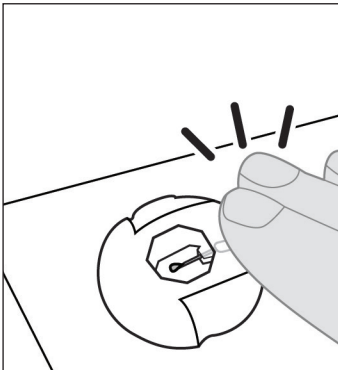

Figure Q

8. **Without lifting the connector from the paper towel, tap the site connector with your finger. This will make any drops break free from the needle tip (see Figure Q).**

Note: Before you attach the connector to the cannula, make sure it is free of drops. If not, it may be hard to detach from the cannula later.

Note: Some infusion sets come with protective caps. These caps allow you to recap the site connector and recap the cannula until it is time to connect them.

2.7 Insert Cannula into the Body

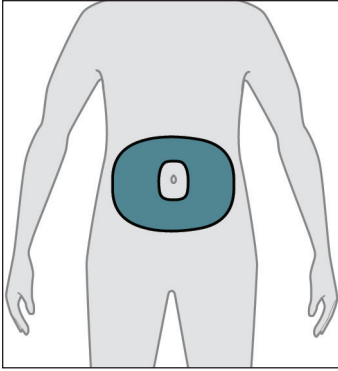

Figure R

- 1. Select the infusion site you want. This could be if it is not already inserted, or if the time has passed that your healthcare provider told you to change it.**

Note: The next instructions describe how to put the cannula into your stomach (abdomen). Your healthcare provider may suggest you put the cannula into another part of your body.

- Choose an area (see Figure R) at least 2 inches (5 cm) from the belly button and at least 1 inch (2.5 cm) from the last insertion site. Change the infusion site every time you change the infusion set. Try not to repeat the last used site for at least 12 days.

Note: Keep at least 2 inches (5 cm) from any areas of scarred or hardened tissue, stretch marks, skin folds or creases where the body naturally bends (e.g., while sitting or exercising), or where clothing might cause irritation (e.g., near the belt-line).

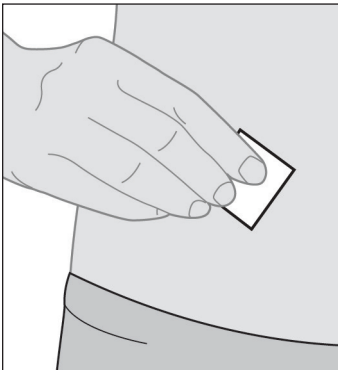

Figure S

- 2. Wipe the infusion site with an alcohol pad (see Figure S).**
 - Let the infusion site dry for at least 1 minute.

Note: It is important to allow it to dry fully or else the adhesive liner may not stick to the skin.

- 3. Insert cannula into the body only.**



Infusion Set

Please refer to your ***Infusion Set Instructions For Use*** for detailed steps.

Note: After you insert the cannula, pat down the adhesive liner to make sure it is stuck well to the skin.

Note: After the cannula is attached, check it regularly. Make sure that there is no fluid leaking out on the skin. If the adhesive liner becomes loose, replace the cannula as this may mean that the cannula is not fully inserted under the skin.

Note: If the infusion set tubing and insertion device/cannula are packaged alone and you need only one of them, you can save the other for later use. If they are packaged together, you must throw away the one not used.

2.8 Connect Infusion Set Tubing to Cannula



Infusion Set

1. Connect the infusion set tubing to the cannula.

Please refer to your *Infusion Set Instructions For Use* for detailed steps.

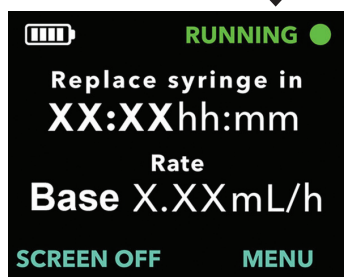
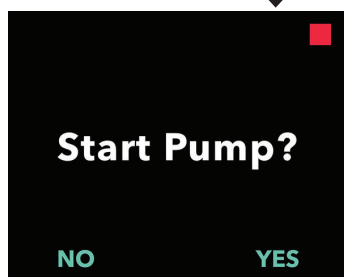
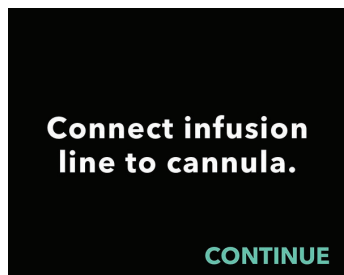

2. Confirm the infusion set tubing is connected to the cannula.

- Press CONTINUE. The pump will return to the status screen.

Note: When you connect the infusion set tubing to the cannula, make sure it snaps securely in place so it does not leak.

3. Start Pump.

Note: When the infusion set tubing is connected to the body, **do not** leave the infusion set tubing hanging loose. Loose tubing could catch on objects by accident. If this happens, the cannula could detach from the infusion site.

3. Administer Therapy

3.1 Start Continuous Infusion Delivery

Note: Always do the following checks before you start an infusion:

1. Verify that the infusion set tubing is connected to the syringe the right way.
2. Verify that the infusion line has no kinks or other blockage.

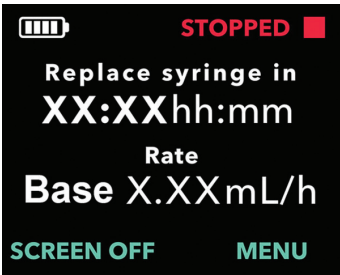

1. Turn on the pump display.

- a. Press any button (arrow keys or selection buttons).
- b. Press MENU to display the pump menu options.

Note: The pump will display the time left until the syringe is empty at the current rate or the time left until the VYALEV still in the syringe should be thrown away and replaced with a new syringe.

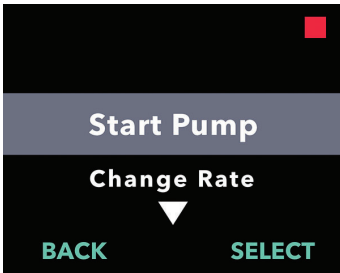

2. Enter the Start Pump menu.

- a. Press SELECT.

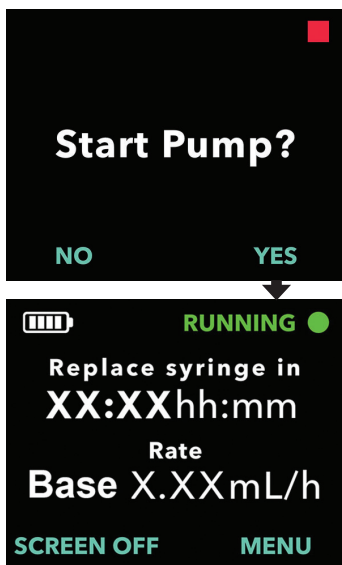

Carrying Accessory

3. Confirm pump start.

- a. Press YES.

Note: If loading dose is set up on your pump and if the loading dose lockout time has passed, the pump will show a screen to allow a loading dose. Unlike an extra dose, you cannot start the loading dose until the pump shows that it is available (see section **Administer Loading Dose**).

4. Insert the pump into the carrying accessory.

Please refer to your **Carrying Accessory Instructions For Use** for detailed steps.

Note: **Do not** use the carrying accessory if it is damaged.

3.2 Stop and Resume Therapy

Note: If therapy is stopped for more than 1 hour, replace the cannula and infusion set tubing. Blockage may occur if you do not replace them.

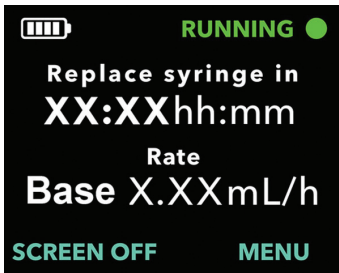

1. Turn on the pump display if needed.

- Press any button (arrow keys or selection buttons).
- Press MENU to display the pump menu options.

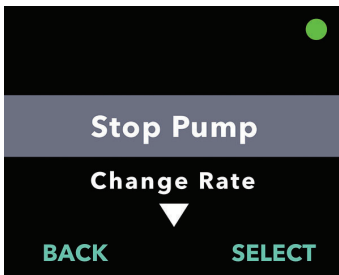

2. Enter the Stop Pump menu.

- Press SELECT.

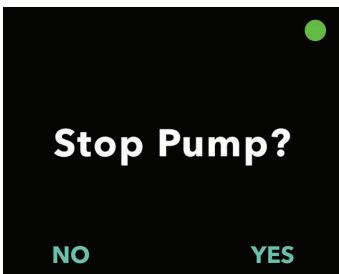

3. Confirm pump stop.

- Press YES.

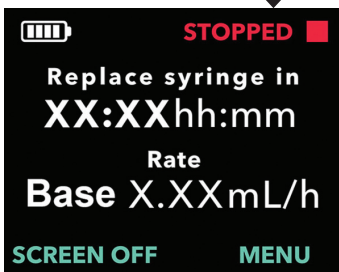

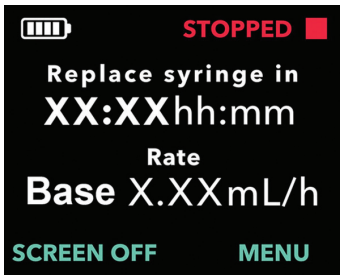

4. When ready, resume the therapy.

- a. Press MENU to show the pump menu options.

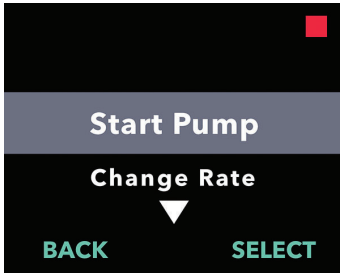

5. Start the pump.

- a. Press SELECT.

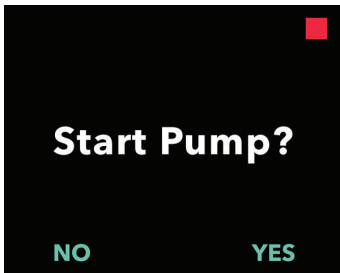

6. Confirm pump start.

- a. Press YES.



3.3 Change the Rate

Note: Your pump may be set up to allow you to change the flow rate. Contact your healthcare provider if you are not sure if this option is available.



1. Turn on the pump display if needed.

- Press any button (arrow keys or selection buttons).
- Press MENU to display the pump menu options.

Note: You do not need stop the pump to change the rate.

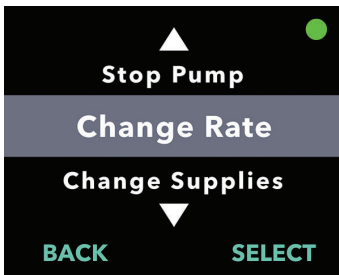

2. Use the arrow keys to highlight the Change Rate menu option.

- Press SELECT to choose the option *Change Rate* and then follow the instructions on the display.

Note: If this option has not been set up by your healthcare provider, this menu option will not be displayed.

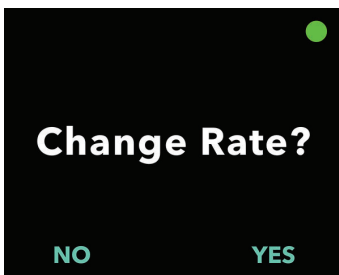

3. Confirm you want to change the rate.

- Press YES.

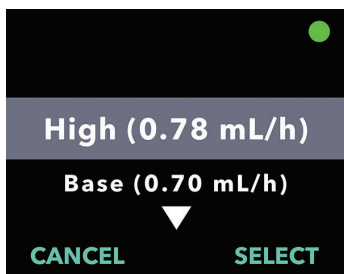

4. Use the arrow keys to select the rate you want.

- a. Press SELECT to choose the highlighted rate.

Note: The available rate options will depend upon the prescription provided by your healthcare provider. In addition to the base rate, you may also have a high and/or low rate. Only the rates prescribed by your healthcare provider will be displayed on your pump screen.

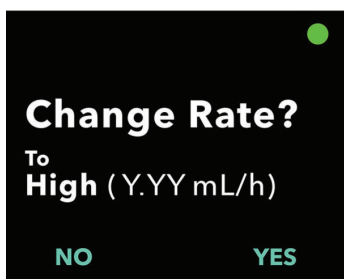

5. Confirm the rate change.

- a. Press YES. The pump should now display the new rate on the status screen.

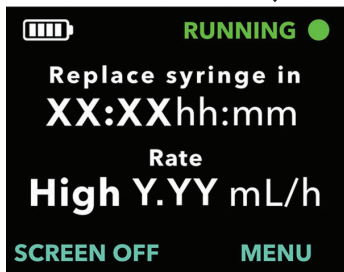

3.4 Administer Extra Dose

Note: Your pump may be set up to allow you to administer an extra dose. Contact your healthcare provider if you are not sure if this option is available.

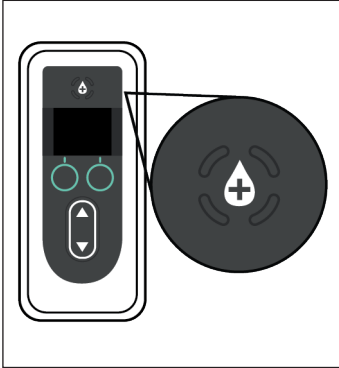

Figure T

1. **While the pump is delivering a continuous infusion, press the extra dose button (see Figure T).**

Note: The pump must be delivering the continuous infusion to administer an extra dose.

Note: If it is too soon for the next extra dose (the extra dose is locked out), the display will show *Extra Dose will be available in: x hours:y minutes*.

Note: If the extra dose feature is not available, the display will show *Extra Dose is not enabled*.

Note: If there is not enough VYALEV left in the syringe to give an extra dose, you will need to change the syringe before an extra dose can be delivered.

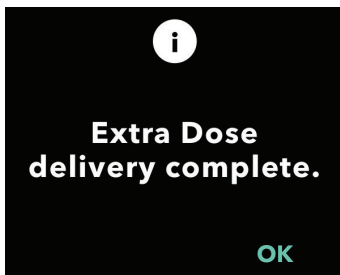
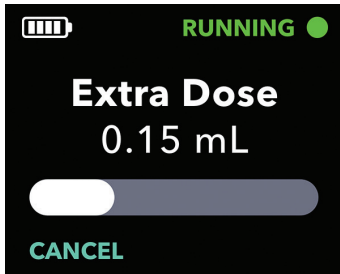
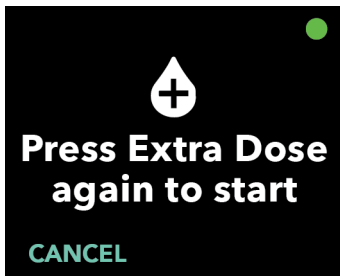

2. Start the dose.

Press the extra dose button a second time.

Note: The pump will ring a tone when the extra dose is starting.

Note: A status bar will appear that will fill with white to show the progress of the extra dose being delivered.

Note: The pump will ring a tone when the extra dose is complete.

3. Press OK when the extra dose is complete to return to the status screen.

Note: If you **do not** press OK within 20 seconds, the pump will begin your continuous infusion again.

3.5 Stop/Cancel Extra Dose Delivery

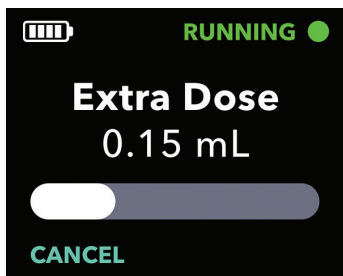

1. **Cancel the extra dose after it has started.**

- a. Press CANCEL.

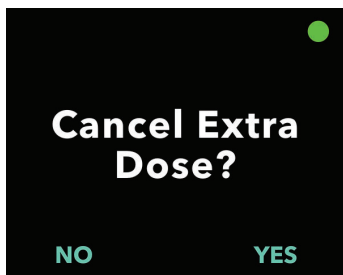

2. **Confirm cancel extra dose.**

- a. Press YES.

Note: If you cancel the extra dose, it cannot be resumed. You cannot start the next extra dose until the lockout time has passed.

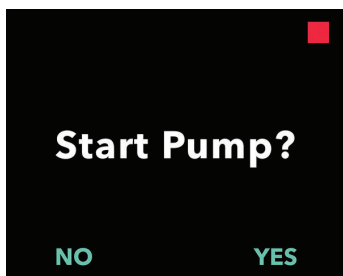

3. **Resume continuous infusion.**

- a. Press YES.

Note: Press NO only if you **do not** want to resume the continuous infusion..

3.6 Administer Loading Dose

Note: Your pump may be set up to offer you a loading dose when the pump has not been giving you medicine for a long time.

Note: Recall that if therapy is stopped for more than 1 hour, you must replace the cannula and infusion set tubing.

Note: To see if loading dose is available, you must select "Start Pump." If loading dose is available, the display screen will show it as an option. You cannot start loading dose unless the pump displays that it is available.

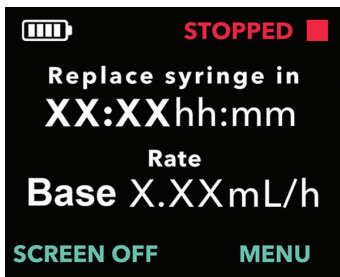

1. Turn on the pump display.

- a. Press any button (arrow keys or selection buttons).
- b. Press MENU to display the pump menu options.

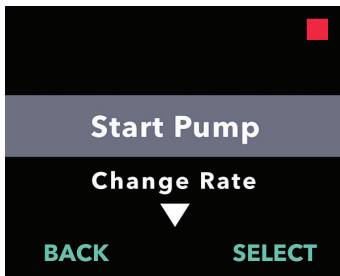

2. Enter the Start Pump menu.

- a. Press SELECT.

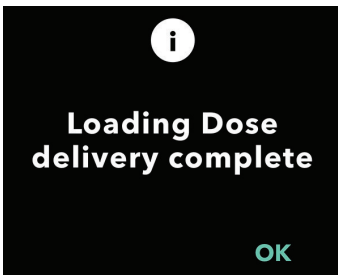
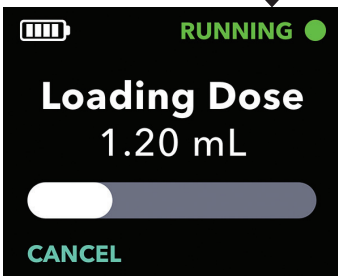
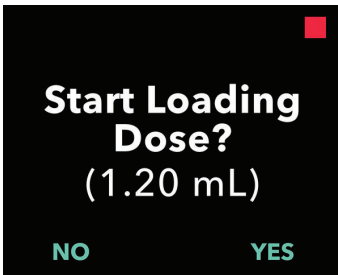

3. Start Loading Dose.

- a. Press YES.

Note: A progress bar will appear and begin to show the progress of the loading dose being delivered.

Note: If the lockout time from the last loading dose has not passed, the pump will not show the option to start a loading dose.

- b. After delivery of the loading dose is complete, the continuous infusion will start. Press OK to return to the status screen.

Note: If you **do not** press OK, the display will return to the status screen after 20 seconds.

3.7 Stop/Cancel Loading Dose

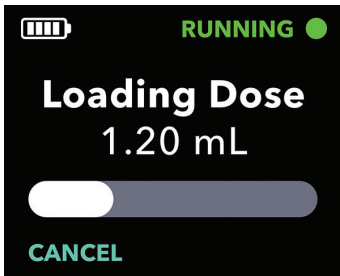

1. Cancel the loading dose after it has started.
 - a. Press CANCEL.

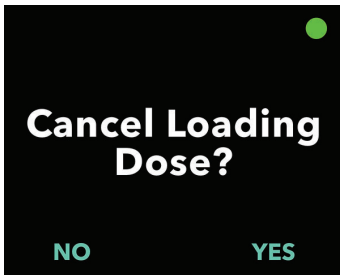

2. Confirm cancel loading dose.
 - a. Press YES. The pump will return to its stopped state.

Note: If you cancel the loading dose, the pump will stop delivery and will not start the continuous infusion.

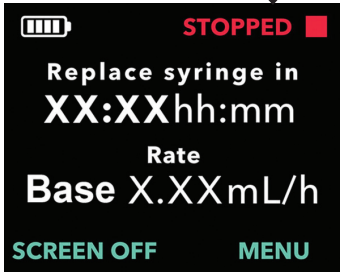

3.8 Resume Loading Dose

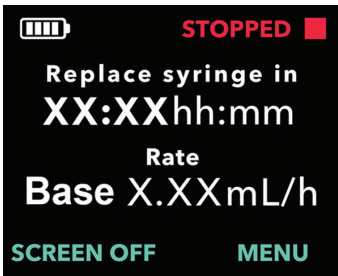

1. Turn on the pump Display.

- Press any button (arrow keys or selection buttons).
- Press MENU to display the pump menu options.

Note: If you cancel the loading dose and start a continuous infusion, the loading dose option will not show until the lockout time has passed.

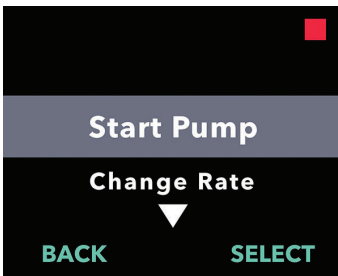

2. Enter the Start Pump menu.

- Press SELECT.

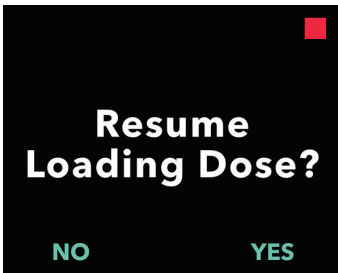

3. Resume loading dose.

- Press YES.

Note: The loading dose will continue from the point where it was canceled.

Note: If you select NO, you will have the option to start a continuous infusion.

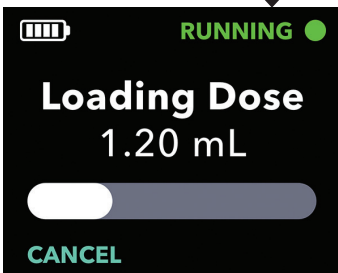

3.9 Choosing to not start loading dose

Note: If you select NO, the pump will prompt you to confirm you **do not** want the loading dose.

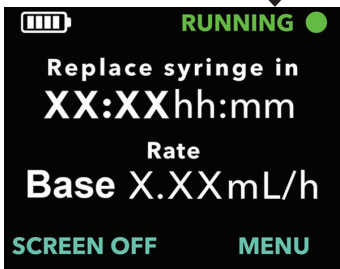
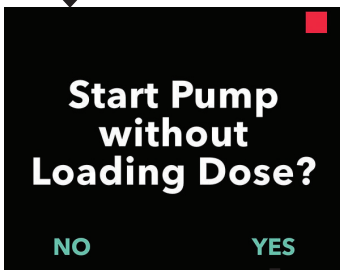
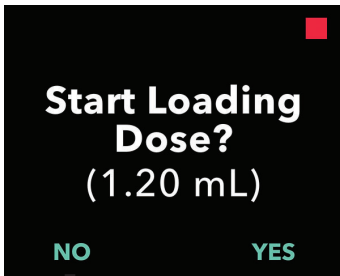

4. Disconnect and Reconnect From Pump



Infusion Set

Please refer to your **Infusion Set Instructions for Use** in this section.

4.1 Disconnect from the Pump (less than 1 hour)

You will need to disconnect from your pump for a short time, for example, when taking a shower.

Note: If therapy is stopped for more than 1 hour, replace the cannula and infusion set tubing. Blockage may occur if you do not.

Warning: Do not let the tip of any disposable part come into contact with any surfaces that are not clean. This will help reduce the risk of infections. If a tip of the infusion set tubing or syringe comes into contact with any surface that is not clean, throw it away and get a new one.

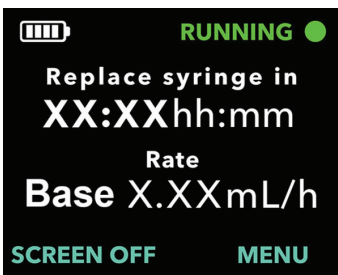

1. Turn on the pump display if needed.

- Press any button (arrow keys or selection buttons).
- Press MENU to display the pump menu options.

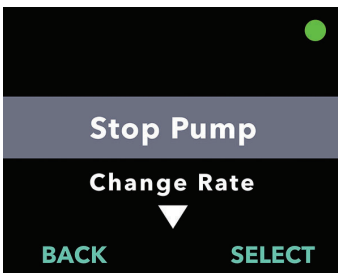

2. Enter the Stop Pump menu.

- Press SELECT.

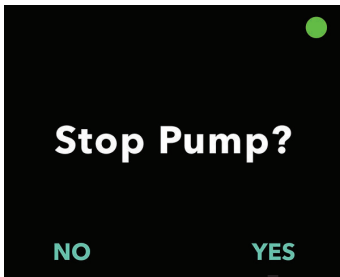

3. Confirm pump stop.

- a. Press YES.

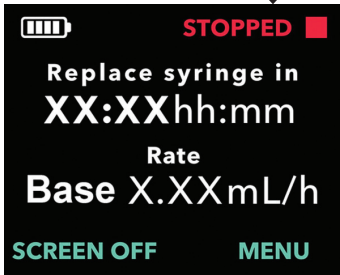

4.2 Disconnect from Site Connector and Remove Drips



Infusion Set

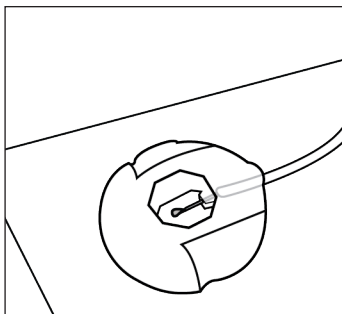

Figure U

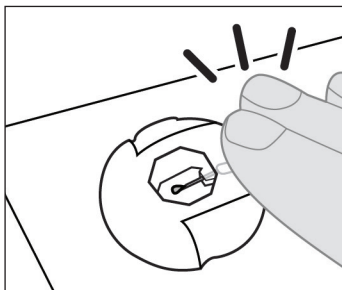

Figure V

1. Disconnect the infusion set tubing from the cannula.

Please refer to your *Infusion Set Instructions For Use* for detailed steps on disconnection.

- a. After they are disconnected, **make sure the needle tip of the connector is showing**. Make sure the tip is not touching any surfaces that are not clean.
- b. Place the connector onto a clean paper towel to make sure it remains clean (see *Figure U*).

Note: When you are disconnected and not using the pump, keep the connector on the clean paper towel until you are ready to reconnect.

- c. Hold the tubing and site connector in place with one hand, wait 60 seconds for the drips to stop. Then tap the connector to remove any drips (see *Figure V*).

Note: Some infusion sets come with protective caps. These caps allow you to recap the site connector and recap the cannula while disconnected.

4.3 Reconnect to Pump (within 1 hour)

1. When you are ready to resume therapy, make sure there are no drops on the needle tip.
2. Without lifting the connector from the paper towel, tap the site connector with your finger. This will make any drops break free from the needle tip.

Note: Before you attach the connector to the cannula, make sure it is free of drops. If not, it may be hard to detach from the cannula later.



Infusion Set

3. Reconnect the infusion set tubing to the cannula.

Please refer to your *Infusion Set Instructions For Use* for detailed steps.

- a. Lift the site connector off of the paper towel.
- b. Reconnect the site connector to the cannula.

Note: If you see a hanging drop from the needle, put the site connector back on the paper towel. Then tap the connector to remove the hanging drop.

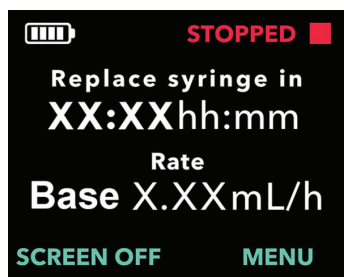

4. Restart the continuous infusion.
 - a. Press MENU to display the pump menu options.

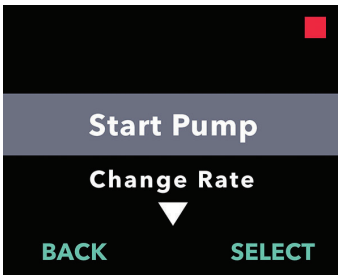

5. Enter the *Start Pump* menu.

- a. Press SELECT.

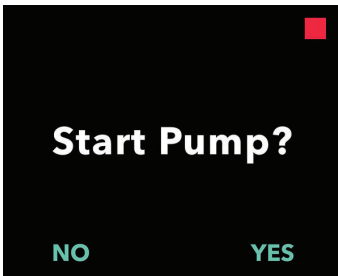

6. Confirm pump start.

- a. Press YES.

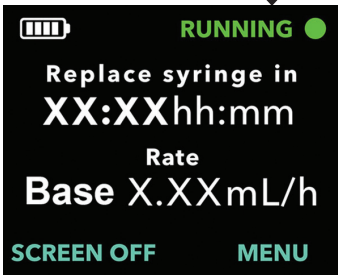

THIS PAGE IS INTENTIONALLY LEFT BLANK.

5. Replace Syringe Only



Instructions for Use of VYALEV, Carrying Accessory, Infusion Set

Please refer to your ***Instructions for Use of VYALEV, Carrying Accessory Instructions for Use, and Infusion Set Instructions for Use*** in this section.

You will change your syringe at least every 24 hours. This will be because 24 hours has passed since the syringe was inserted into the pump or because the syringe is empty or nearly empty.

Note: If you are replacing only the syringe and are using the same tubing, you will not need to prime. This is because the tubing will already be filled with VYALEV.

Note: You should prepare your new syringe while the pump is delivering VYALEV. This is so your therapy will not be interrupted. The infusion set tubing can stay connected to the cannula when you are replacing the syringe only.

Note: If therapy is stopped for more than 1 hour, replace the cannula and infusion set tubing. If not, blockage may occur.

5.1 Gather Supplies

1. Select a clean, flat workspace.
2. Gather supplies, including (see *Figure W*):

- Pump
- Syringe
- New, unused paper towels
- Solution vial
- Vial adapter*
- Alcohol pads

Note: Always make sure that you have replacements for all of your disposal parts.

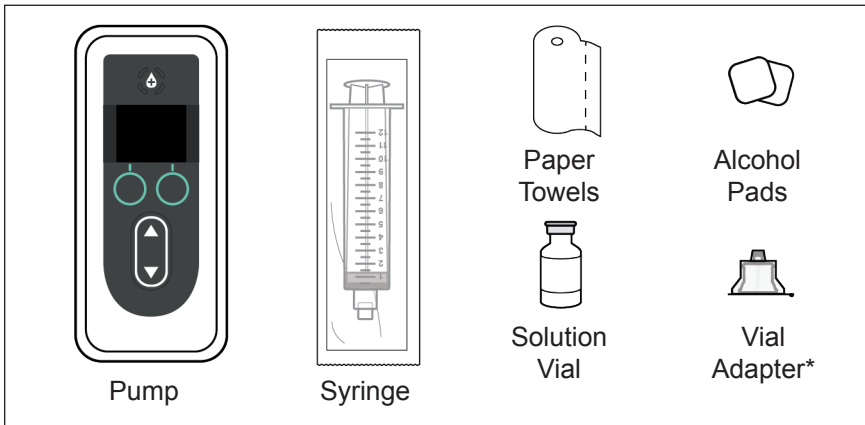

Figure W

*Your vial adapter may look different from the one shown in *Figure W*.

Note: If refrigerated, make sure you warm the solution vial at room temperature for 30 minutes before you fill the syringe.

3. Inspect parts.

- a. Inspect and verify that all parts have not expired and that there is no damage to any of the packaging. If any of the parts have expired or if the packaging is damaged, **do not** use them. Contact your healthcare provider.
- b. Inspect the contents of the solution vial. Verify that you **do not** see cloudiness or particles in the liquid.

Note: The packaging for the vial adapter and syringe state that they are sterile. The packaging also states how they were sterilized.

Warning: Verify that the solution is VYALEV as prescribed by your healthcare provider.

Warning: Check the expiration date for all disposable parts. **Do not** use a part if it is expired.

Warning: **Do not** use any disposable parts if their sterile packaging has been damaged before use.

Caution: Inspect all disposable parts before use. **Do not** use any of them if they are damaged.

Caution: **Do not** use the VYALEV if it is cloudy or contains flakes or particles.



Figure X

4. Wash your hands with soap and water and dry them (see *Figure X*).

5.2 Fill Syringe with VYALEV

1. Find a well-lit area and a flat surface like a table.

Note: To reduce the risk of infection, make sure your work surface is clean.

Note: When changing supplies, it is important to follow the display screens. This will help make sure that the pump is properly set up for the infusion.



***Instructions for
Use of VYALEV***

2. Prepare the syringe.

Please refer to your ***Instructions for Use of VYALEV*** for detailed steps on how to:

- Connect the vial adapter to the solution vial
- Transfer the VYALEV from the solution vial to the syringe
- Remove air bubbles
- Remove all air from the syringe

5.3 Stop Therapy



Carrying Accessory

1. If you are using a carrying accessory, remove the pump.

Please refer to your **Carrying Accessory Instructions For Use** for detailed steps.

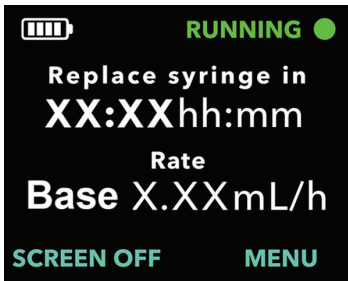

2. Turn on the pump display.
 - a. Press any button (arrow keys or selection buttons).
 - b. Press MENU to display the pump menu options.



3. Use the arrow keys to highlight the **Change Supplies** menu option.
 - a. Press SELECT to choose the option to change supplies. Then follow the instructions on the display.

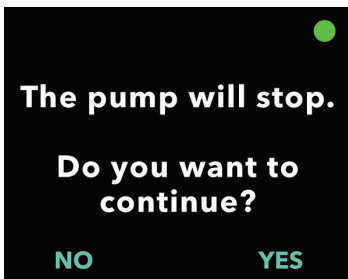

4. Stop the infusion.
 - a. Press YES.

5.4 Remove Used Syringe from Pump

Note: When the screen shows the option of "Remove Syringe," select that option before you open the pump lid.



1. Enter the *Remove Syringe* menu.

- a. Press SELECT.

Note: **Do not** open the lid until indicated on the display (see step 3).

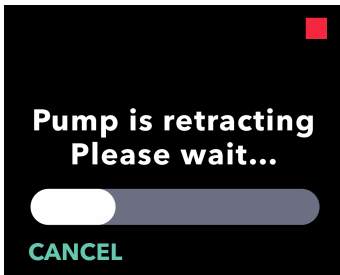

2. Pause to allow the pump plunger to retract.

Note: The status bar indicates the progress of the pump plunger while it is retracting.

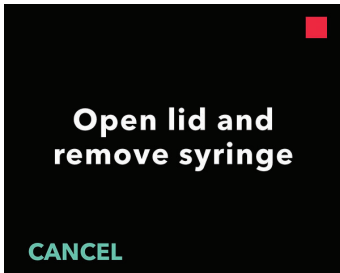

3. When the pump display prompts you (see *Figure Y*), open the lid of the pump and remove the used syringe.

Figure Y

5.5 Replace the Syringe

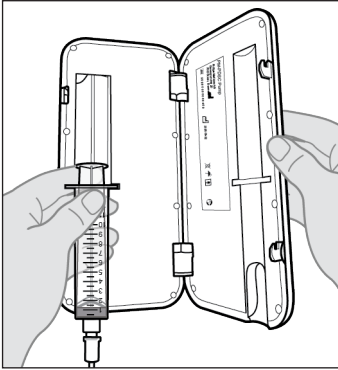

Figure Z

1. Remove the used syringe from the pump (see *Figure Z*).

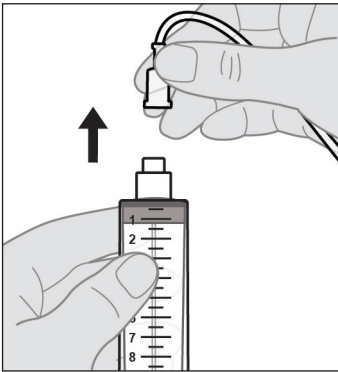

Figure AA

2. Disconnect the infusion set tubing from the used syringe (see *Figure AA*).
3. Throw away the used syringe per local regulations.

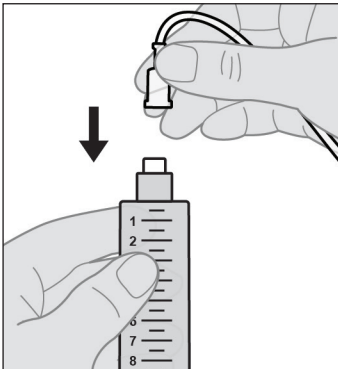

Figure AB

4. Attach the infusion set tubing to the new syringe (see *Figure AB*).

5.6 Place New Syringe in Pump

Note: When replacing only the syringe and not the tubing, you **do not** need to prime the tubing.

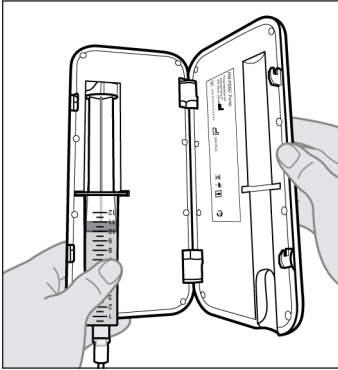
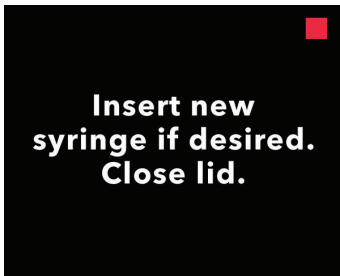

Figure AC



1. Place the new syringe into the pump.

- a. Place the syringe into the pump groove with the syringe flanges in the syringe flange grooves (see Figure AC).

Note: The syringe should fit into the pump groove with little to no resistance. If the syringe does not fit inside the pump groove, check to see if the syringe plunger has moved to the right place and air has been removed.

Note: Make sure the syringe is correctly seated in the pump before closing the pump lid.

If there is still air in the syringe tip, the syringe may not fit into the pump. If this happens, make sure the tubing is not connected to the cannula. Then carefully push out the rest of the air. Be careful not to also push out any of the VYALEV.

Close the pump lid until it snaps shut and the syringe is secured in place.

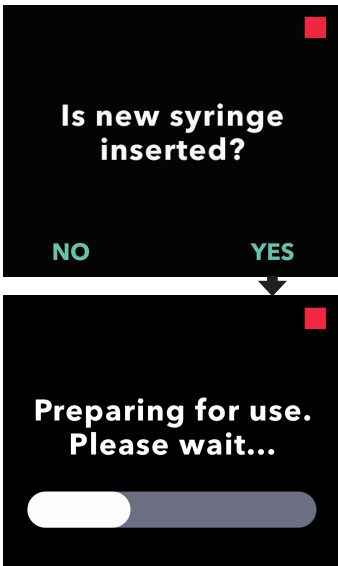

2. Confirm that the new syringe has been inserted.

- a. Press YES.
- b. Pause to allow the pump to prepare the new syringe for use.

5.7 Resume Continuous Infusion Delivery

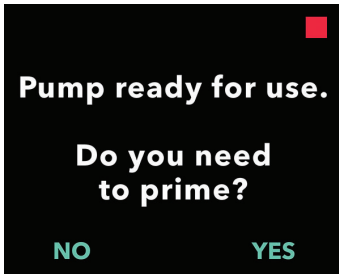

Note: If you replaced only the syringe and not the tubing, select “no” because you do not need to prime the tubing.

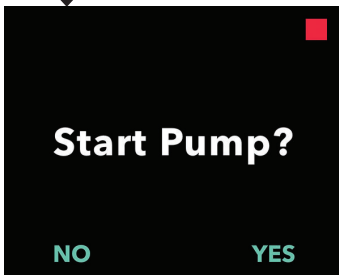

1. Start Pump

Note: Make sure your infusion set tubing is connected to the cannula before starting the pump.

Note: Always perform the following checks before you start an infusion:

1. Verify that the infusion set is correctly connected to the syringe.
2. Verify that the infusion line has no kinks or other blockage.

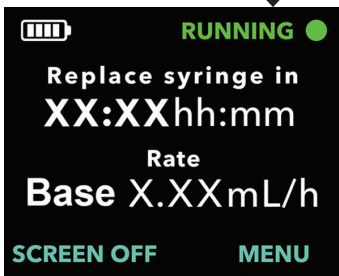

6. Replace Infusion Set Tubing and Cannula (not Syringe)



Please refer to your **Infusion Set Instructions for Use** and **Insertion Device Instructions for Use** in this section.

Infusion Set and Insertion Device

The cannula and infusion set tubing must be changed at regular periods, as per the instructions from your healthcare provider. They must also be changed when there is a blockage or leak that cannot be fixed any other way.

6.1 Gather Supplies

1. Select a clean work space.

2. Gather supplies (see **Figure AD**).

- Pump
- Infusion set
- Insertion device
- Alcohol pads
- New, unused paper towels

Note: Always make sure that you have replacements for all of your disposable parts.

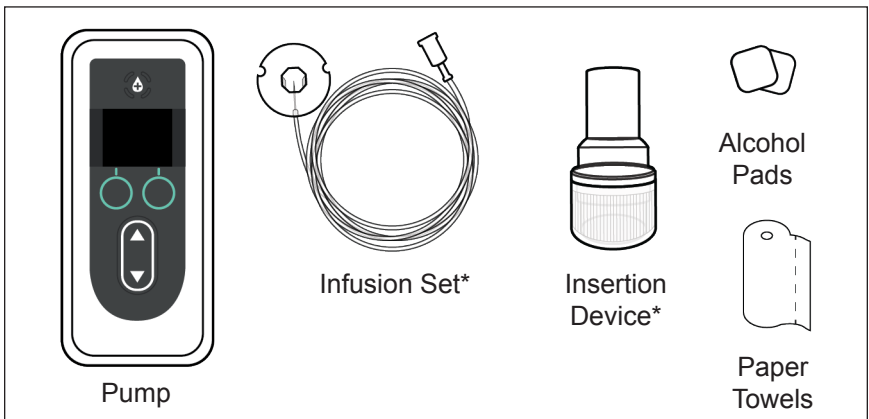

Figure AD

*Your insertion device and infusion set may look different from the ones shown in **Figure AD**.

3. Inspect parts for expiration and for any packaging damage.

Note: The product packaging for the infusion set indicates that it is sterile and how it was sterilized.

Warning: Check expiration date for all disposable parts. **Do not** use a part if it is expired.

Warning: **Do not** use any disposable parts if their sterile packaging has been damaged before use.

Caution: Inspect all disposable parts before use. **Do not** use any of them if they are damaged.

Caution: **Do not** use VYALEV if it has been in the syringe for more than 24 hours.

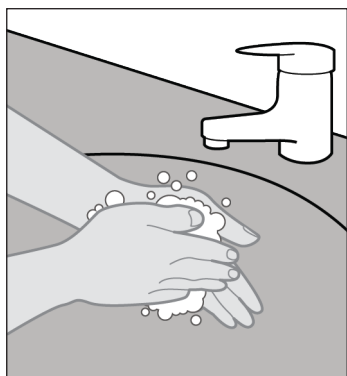
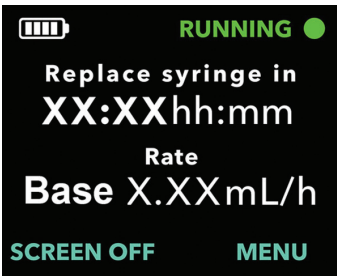

Figure AE

4. Wash your hands with soap and water and dry them (see *Figure AE*).

6.2 Stop Therapy



1. Turn on the pump display if needed.
 - a. Press any button (arrow keys or selection buttons).
 - b. Press MENU to display the pump menu options.

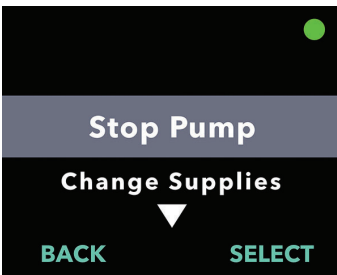

2. If the pump is running, press **SELECT** to choose the Stop Pump menu.

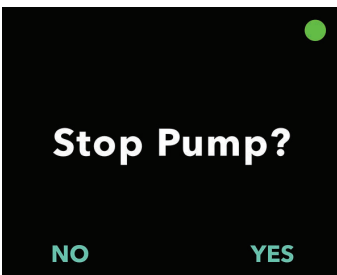

3. Confirm pump stop.
 - a. Press YES.

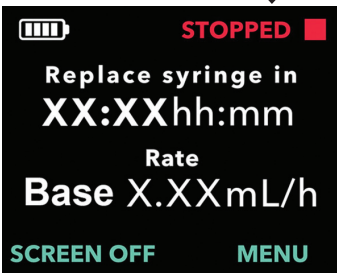

6.3 Remove Cannula and Disconnect Infusion Set Tubing from Syringe



Infusion Set

1. Remove cannula and disconnect infusion set tubing from syringe.

Please refer to your *Infusion Set Instructions For Use* for detailed steps.

2. Discard the used infusion set tubing and cannula per local regulations.

6.4 Connect New Infusion Set Tubing



Infusion Set

1. Remove infusion set tubing from the package.

Please refer to your *Infusion Set Instructions For Use* for detailed steps.

2. Attach the infusion set tubing to the syringe.

- a. While holding the pump firmly, attach the infusion set tubing to the syringe. Twist until snug (see *Figure AF*).

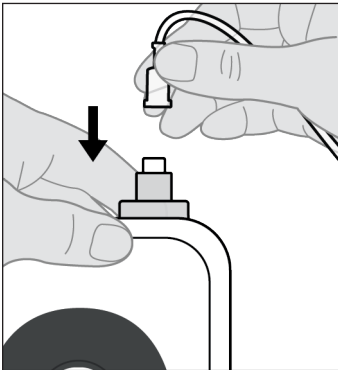
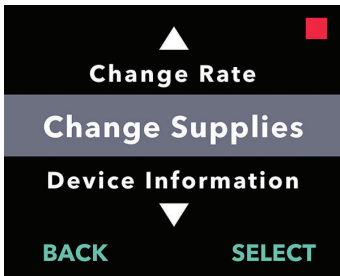

Figure AF

- Warning:** Do not let the tip of any disposable part come into contact with any surfaces that are not clean. This will help to reduce the risk of infections. If a tip of the infusion set tubing or syringe comes into contact with a surface that is not clean, throw it away and get a new one.

6.5 Prime Infusion Set Tubing



1. **Select MENU, then use the arrow keys to highlight the Change Supplies menu option.**
 - a. Press SELECT to choose the option to *Change Supplies*. Then follow the instructions on the display.

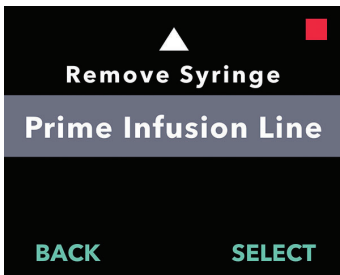

2. **Use the arrow keys to highlight the Prime Infusion Line menu option.**
 - a. Press SELECT to enter menu.

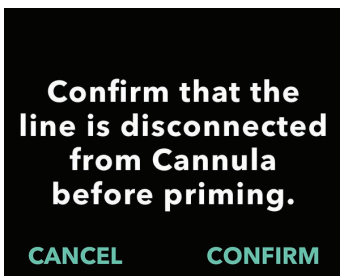

3. **Confirm the infusion line is not connected to the cannula.**
 - a. Press CONFIRM.

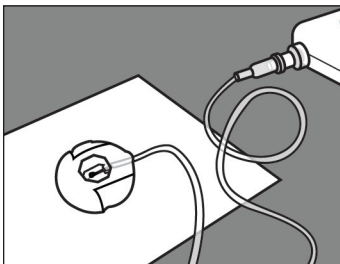

Figure AG

4. **Prepare to prime the infusion set.**
 - a. Lay the needle end of the Infusion set on a clean paper towel. This is so that the drops will fall on the paper towel and will not fall onto any part of the connector (see *Figure AG*).

Note: Your infusion set may look different from the one shown here.

Note: You may need to stabilize the tubing by holding it with your finger.



Figure AH

**Hold pump
with syringe tip
straight up**



PRIME

**Press and release
to prime**

5. Prime the infusion set.

- a. Hold the pump with the syringe tip straight up (see *Figure AH*).

Note: The display will rotate so that you can read it when the pump is held this way for priming.

- b. Press PRIME.

Note: The pump must be pointing straight up and not tilted or the option PRIME will not appear. Make sure the pump is not tilted.

Note: If the pump is tilted slightly, the display will tell you that the syringe tip must point straight up to be able to prime.

Note: Each time you press PRIME, the pump will deliver a volume of solution into the infusion set and stop.

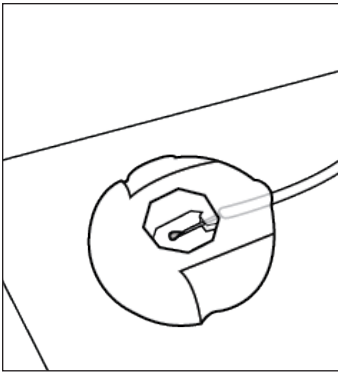

Figure AI

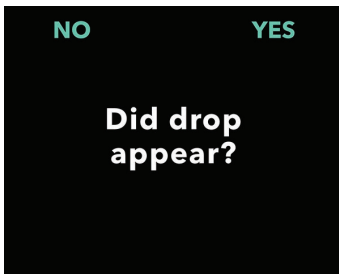
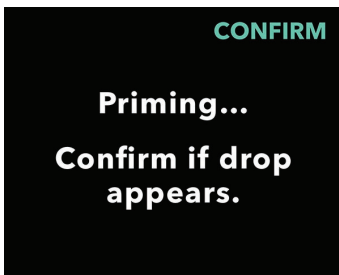

Figure AJ

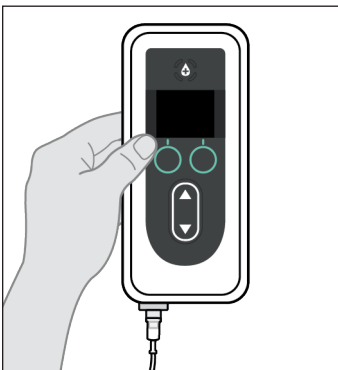

Figure AK

6. Look for a drop of VYALEV on the site connector needle (see *Figure AI*).

- a. Press CONFIRM when you see a drop of VYALEV on the site connector needle.
- b. Press YES to confirm the appearance of the drop.

Note: It may take several seconds for the drop to appear.

Note: If CONFIRM is not pressed, you will be asked if a drop appeared (see *Figure AJ*).

Note: Pressing NO will bring you to the prior screen. This will allow you to continue priming the pump until a drop appears.

7. Return the pump to its original position (see *Figure AK*). Place the pump flat on the table.

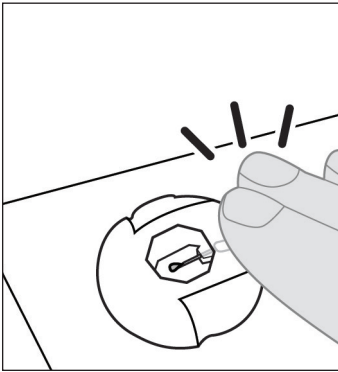

Figure AL

8. After 60 seconds, tap the site connector with your finger. This is so any drops break free from the needle (see *Figure AL*).

Note: Before you attach the connector to the cannula, make sure it is free of drops. If not, it may be hard to detach from the cannula later.

Note: Some infusion sets come with protective caps. These caps allow you to recap the site connector and recap the cannula until it is time to connect them.

6.6 Insert Cannula and Pad or Needle into the Body

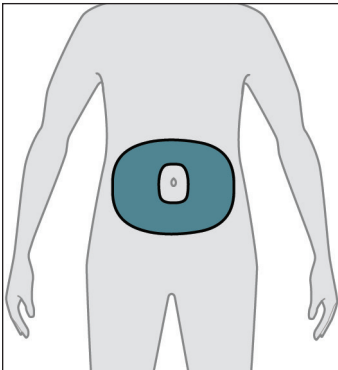

Figure AM

1. Select the infusion site you want.

Note: The next instructions describe how to put the cannula into your stomach (abdomen). Your healthcare provider may suggest you put the cannula into another part of your body.

- a. Choose an area (see *Figure AM*) at least 2 inches (5 cm) from the belly button and at least 1 inch (2.5 cm) from the last insertion site. Change the infusion site every time you change the infusion set. Try not to repeat the last used site for at least 12 days.

Note: Keep at least 2 inches (5 cm) from any areas of scarred or hardened tissue, stretch marks, skin folds or creases where the body naturally bends (e.g., while sitting or exercising), or to areas where clothing might cause irritation (e.g., near the belt-line).

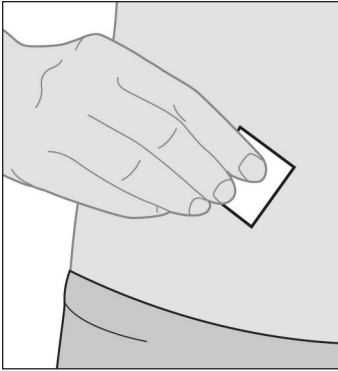

Figure AN

2. Wipe the infusion site with an alcohol pad (see *Figure AN*).

- a. Let the infusion site dry for at least 1 minute.

Note: It is important to allow it to dry fully. If not, the adhesive liner may not stick to the skin.



Infusion Set

3. Insert the cannula into the body only.

Please refer to your ***Infusion Set Instructions For Use*** for detailed steps.

Note: After you insert the cannula, pat down the adhesive liner to make sure it is stuck well to the skin.

Note: After you attach the cannula, check it regularly. Make sure that there is no fluid leaking out on the skin. If the adhesive liner becomes loose, replace the cannula as this may mean that the cannula is not fully inserted under the skin.

Note: If the infusion set tubing and insertion device/cannula are packaged alone and you need only one of them, you can save the other for later use. If they are packaged together, you must throw away the one not used.

6.7 Connect Infusion Set Tubing to Cannula and Resume Continuous Infusion Delivery



Infusion Set

1. Connect infusion set tubing to cannula.

Please refer to your *Infusion Set Instructions For Use* for detailed steps.

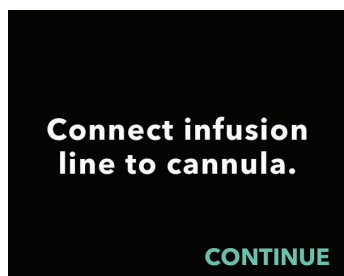

2. Confirm the infusion set tubing is connected to the cannula.

- Press CONTINUE. The pump will return to the status screen.

Note: When you connect the infusion set tubing to the cannula, make sure it snaps securely in place so it does not leak.

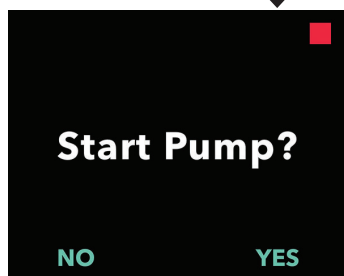

3. Confirm pump start.

- Press YES.

Optional: Place pump into the carrying accessory.

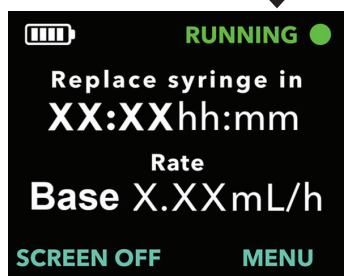

7. Replace Syringe, Infusion Set Tubing, and Cannula



Instructions for Use of VYALEV, Carrying Accessory, Infusion Set

Please refer to your ***Instructions for Use of VYALEV, Carrying Accessory Instructions for Use, and Infusion Set Instructions for Use*** in this section.

The cannula and infusion set tubing must be changed at regular periods, as per the instructions from your healthcare provider. You may also replace the syringe at that time.

Note: You should prepare your new syringe while the pump is delivering VYALEV. This is so your therapy will not be interrupted.

7.1 Gather Supplies

1. Select a clean, flat workspace.
2. Gather supplies, including (see *Figure AO*):

- Pump
- Syringe
- New, unused paper towels
- Insertion device*
- Solution Vial
- Vial Adapter*
- Alcohol pads
- Infusion set*

Note: Always make sure that you have replacements for all of your disposal parts.

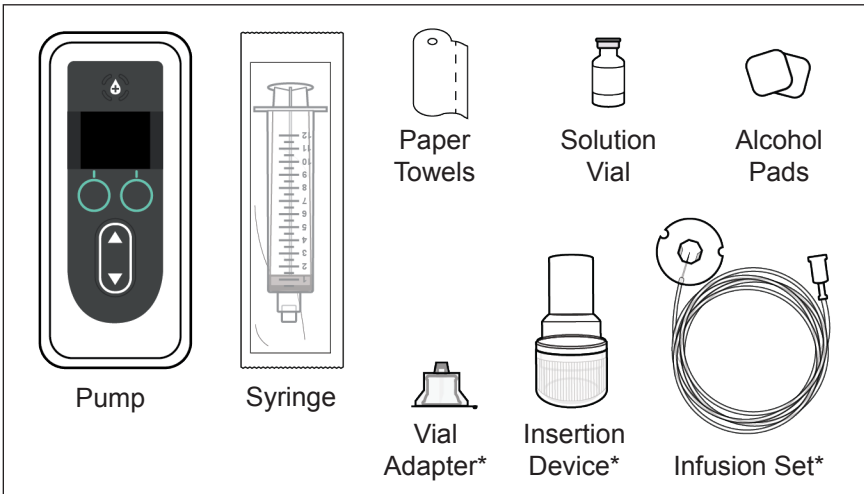

Figure AO

*Your insertion device, infusion set, and vial adapter may look different from the ones shown in *Figure AO*.

Note: If refrigerated, make sure you warm the solution vial at room temperature for 30 minutes before you fill the syringe.

3. Inspect parts for expiration and for any packaging damage.

- a. Inspect and verify that all parts have not expired and that there is no damage to any of the packaging. If any of the parts have expired or if the packaging is damaged, **do not** use, and contact your healthcare provider.
- b. Inspect the contents of the solution vial. Verify that you **do not** see cloudiness or particles in the liquid.

Note: The packaging for the infusion set, vial adapter and syringe state that they are sterile. The packaging also states how they were sterilized.

 **Warning:** Verify that the solution is VYALEV as prescribed by your healthcare provider.

 **Warning:** Check the expiration date for all disposable parts. **Do not** use a part if it is expired.

 **Warning:** **Do not** use any disposable parts if their sterile packaging has been damaged before use.

Caution: Inspect all disposable parts before use. **Do not** use any of them if they are damaged.

Caution: **Do not** use VYALEV if it has been in the syringe for more than 24 hours.

Caution: **Do not** use VYALEV if it is cloudy or contains flakes or particles.



Figure AP

4. Wash your hands with soap and water and dry them (see *Figure AP*).

7.2 Fill Syringe with VYALEV



Instructions for Use of VYALEV

1. Find a well-lit area and a flat surface like a table.

Note: Make sure your work surface is clean to reduce infections.

2. Prepare the syringe.

Please refer to your **Instructions For Use of VYALEV** for detailed steps on how to:

- Connect the vial adapter to the solution vial
- Transfer the VYALEV from the solution vial to the syringe
- Remove air bubbles
- Remove all air from the syringe

7.3 Stop Therapy



Carrying Accessory

1. If you are using a carrying accessory, remove the pump.

Please refer to your **Carrying Accessory Instructions For Use** for detailed steps.

2. Turn on the pump display.

- a. Press any button (arrow keys or selection buttons).
- b. Press MENU to display the pump menu options.

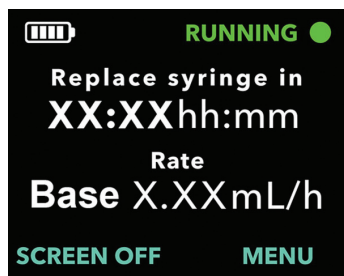

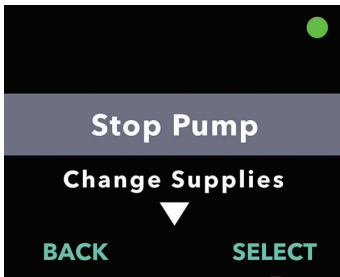

3. If the pump is running, press **SELECT** to enter the Stop Pump menu.

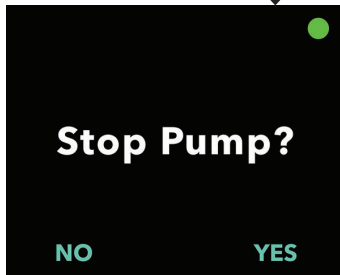

4. Confirm pump stop.
 - a. Press YES.

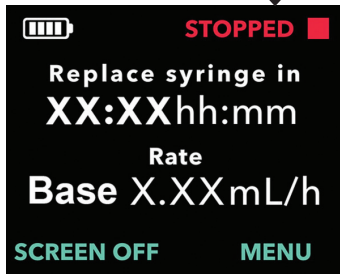

7.4 Remove Cannula from Infusion Site



Infusion Set

1. Remove cannula.

Please refer to your *Infusion Set Instructions For Use* for detailed steps.

7.5 Remove the Used Syringe from Pump

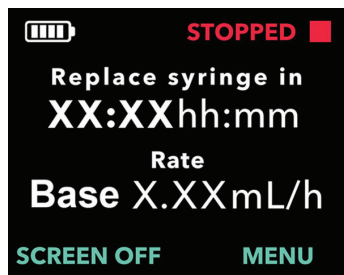

1. Turn on the pump display.
 - a. Press any button (arrow keys or selection buttons).
 - b. Press MENU to display the pump menu options.



2. Use the arrow keys to highlight the Change Supplies menu option.
 - a. Press SELECT to choose the option to Change Supplies. Then follow the instructions on the display.

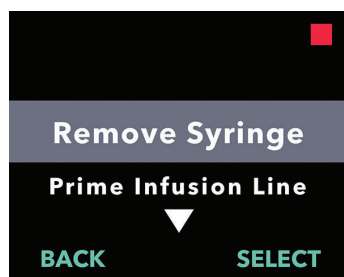

3. Enter the Remove Syringe menu.
 - a. Press SELECT.

Note: Do not open the lid until after you select the Remove Syringe option.

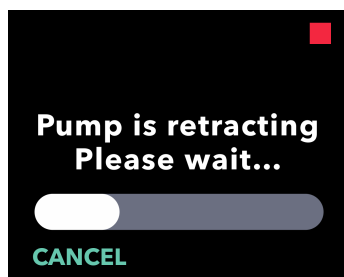

4. Pause to allow the pump plunger to retract.

**Open lid and
remove syringe**

CANCEL

- When the pump display prompts you (see *Figure AQ*), open the lid of the pump and remove the used syringe (see *Figure AR*).

Figure AQ

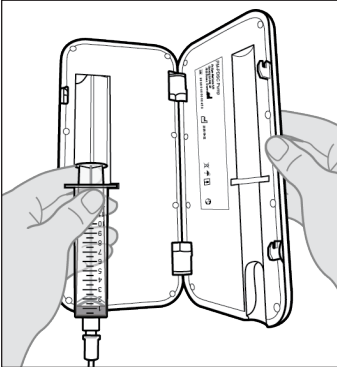

Figure AR

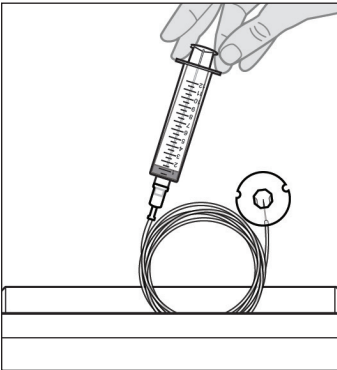

Figure AS

- Throw away the used syringe and infusion set per local regulations (see *Figure AS*).

7.6 Connect New Infusion Set Tubing to New Syringe

1. Remove the infusion set tubing from the package.
2. Attach the infusion set tubing to a new filled syringe (see *Figure AT*).

Note: If needed, refer to section **Fill Syringe with VYALEV**.

Warning: Do not let the tip of any disposable part come into contact with any unclean surfaces that are not clean. This is to help reduce the risk of infections. If a tip of the infusion set tubing or syringe comes into contact with a surface that is not clean, throw it away and get a new one.

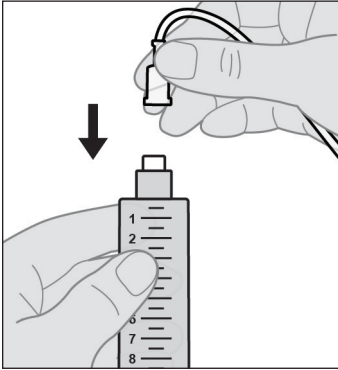

Figure AT

7.7 Place New Syringe in Pump

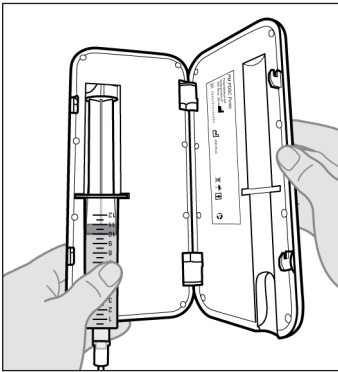

Figure AU

Insert new syringe if desired. Close lid.

Is new syringe inserted?

NO

YES

Preparing for use. Please wait...



1. Place the syringe into the pump.

- Place the syringe into the pump groove with the syringe flanges in the syringe flange grooves (see Figure AU).

Note: The syringe should fit into the pump groove with little to no resistance. If the syringe does not fit inside the pump groove, check to see if the syringe plunger has moved to the right place and air has been removed.

Note: Make sure the syringe is correctly seated in the pump before closing the pump lid.

If there is still air in the syringe tip, the syringe may not fit into the pump, even with a syringe plunger rod that is fully pulled back (retracted). If this happens, re-attach the syringe to the vial adapter that is still attached to the vial. With the vial and syringe pointed upward, slowly push all air that remains and a small amount of liquid back into the vial. Then re-attach the infusion set tubing and try again.

- Close the pump lid until it snaps shut and the syringe is secured in place.

2. Confirm that the new syringe has been inserted.

- Press YES.
- Pause to allow the pump to prepare the new syringe for use.

7.8 Prime Infusion Set Tubing

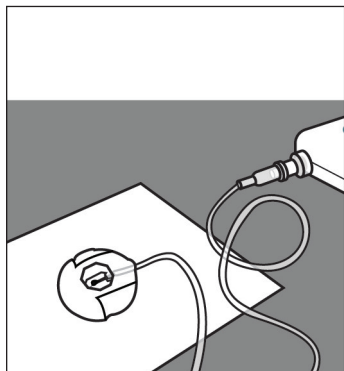
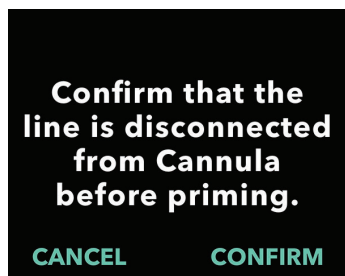
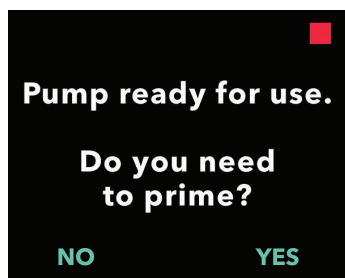

Figure AV



1. Prepare to prime the infusion set.

- a. Lay the needle end of the infusion set on a clean paper towel. This is so that the drops will fall on the paper towel and will not fall onto any part of the connector (see *Figure AV*).

Note: Your infusion set may look different from the one shown here.

Note: You may need to stabilize the tubing by holding it with your finger.

2. Start the priming process.

- a. Press YES.

Note: If the tubing is new, you need to prime it.

Note: Pressing NO will return you to the status screen.

Note: If you need to prime and do not see this screen, from the status screen select "MENU". Scroll to and select "Change Supplies", and then scroll to and select "Prime Infusion Line."

3. Confirm the infusion line is not connected to the cannula.

- a. Press CONFIRM.

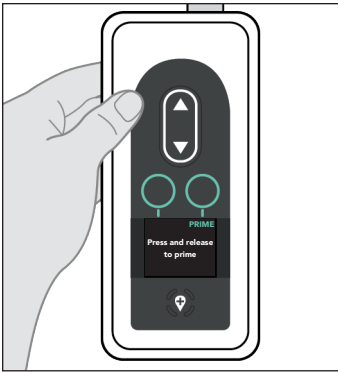

Figure AW

**Hold pump
with syringe tip
straight up**



**Press and release
to prime**

PRIME

4. Prime the infusion set.

- a. Hold the pump with the syringe tip straight up (see *Figure AW*).

Note: The display will rotate so that you can read it when the pump is held this way for priming.

- b. Press PRIME.

Note: The pump must be pointing straight up and not tilted or the option PRIME will not appear. Make sure the pump is not tilted.

Note: If the pump is tilted slightly, the display will tell you the syringe tip must point straight up to be able to prime.

Note: Each time you press PRIME, the pump will deliver a volume of solution into the infusion set and stop.

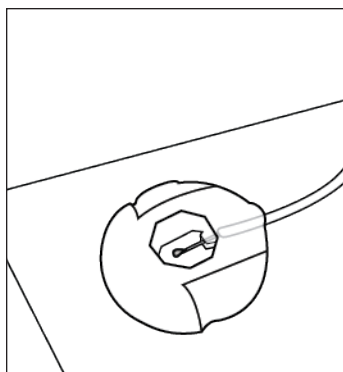

Figure AX

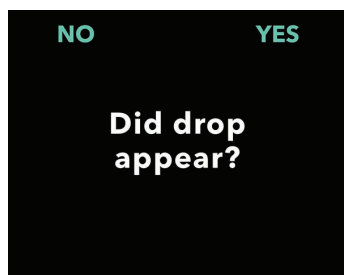
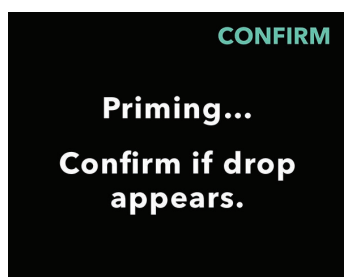

Figure AY

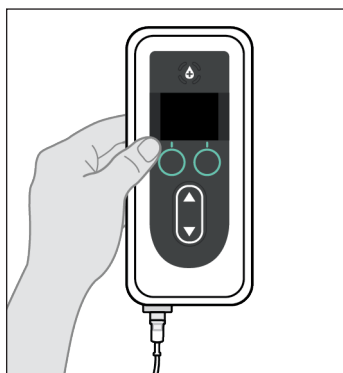

Figure AZ

5. Look for a drop of VYALEV on the site connector needle (see *Figure AX*).

- a. Press CONFIRM when you see a drop of VYALEV on the site connector needle
- b. Press YES to confirm the appearance of the drop.

Note: It may take several seconds for the drop to appear.

Note: If CONFIRM is not pressed, you will be asked if a drop appeared (see *Figure AY*).

Note: Pressing NO will bring you to the prior screen. This will allow you to continue priming the pump until a drop appears.

6. Return the pump to its original position (see *Figure AZ*). Place the pump flat on the table.

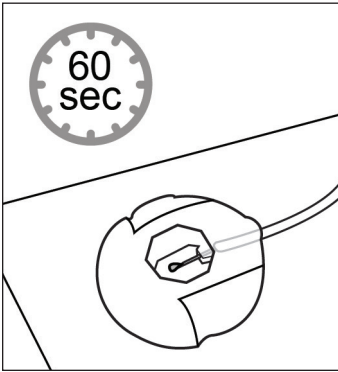

Figure BA

7. **Wait at least 60 seconds to make sure that the VYALEV has stopped dripping from the needle (see Figure BA).**

Note: You **MUST** wait at least 60 seconds for the dripping to stop.

Note: You may need to stabilize the tubing by holding it with your finger.

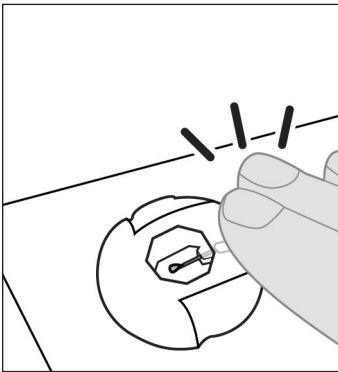

Figure BB

8. **Without lifting the connector from the paper towel, tap the site connector with your finger. This will make any drops break free from the needle tip (see Figure BB).**

Note: Before you attach the connector to the cannula, make sure it is free of drops. If not, it may be hard to detach from the cannula later.

Note: Some infusion sets come with protective caps. These caps allow you to recap the site connector and recap the cannula until it is time to connect them.

7.9 Insert Cannula into the Body

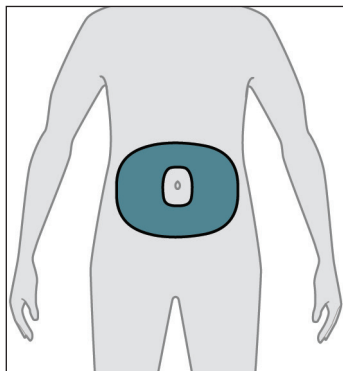

Figure BC

1. Select your desired infusion site.

Note: The next instructions describe how to put the cannula into your stomach (abdomen). Your healthcare provider may suggest you put the cannula into another part of your body.

- a. Choose an area (see *Figure BC*) at least 2 inches (5 cm) from the belly button and at least 1 inch (2.5 cm) from the last insertion site. Change the infusion site every time you change the infusion set. Try not to repeat the last used site for at least 12 days.

Note: Keep at least 2 inches (5 cm) from any areas of scarred or hardened tissue, stretch marks, skin folds or creases where the body naturally bends (e.g., while sitting or exercising), where clothing might cause irritation (e.g., near the belt-line).

2. Wipe the infusion site with an alcohol pad (see *Figure BD*).

- a. Let the infusion site dry for at least 1 minute.

Note: It is important to allow it to dry fully. If not, the adhesive liner may not stick to the skin.

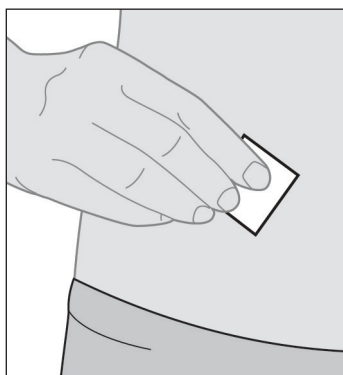

Figure BD



Infusion Set

3. Insert the cannula into the body only.

Please refer to your ***Infusion Set Instructions For Use*** for detailed steps.

Note: After you insert the cannula, make sure the adhesive liner is stuck well to the skin.

Note: After you attach the cannula, check it regularly. Make sure that there is no fluid leaking out on the skin. If the adhesive liner becomes loose, replace the cannula as this may mean that the cannula is not fully inserted under the skin.

Note: If the infusion set tubing and insertion device/cannula are packaged alone and you need only one of them, you can save the other for later use. If they are packaged together, you must throw away the one not used.

7.10 Connect Infusion Set Tubing to Cannula and Resume Continuous Infusion



Infusion Set

1. Connect infusion set tubing to cannula.

Please refer to your *Infusion Set Instructions For Use* for detailed steps.

Connect infusion line to cannula.

CONTINUE

2. Confirm the infusion set tubing is connected to the cannula.

a. Press CONTINUE.

Note: When you connect the infusion set tubing to the cannula, make sure it snaps securely in place so it does not leak.

Start Pump?

NO

YES

3. Start pump.

Note: Always perform the following checks before you start an infusion:

1. Verify that the infusion set tubing is correctly connected to the syringe.
2. Verify that the infusion line has no kinks or other blockage.
3. Press YES to start the pump (the pump will return to the status screen).

Note: Press NO to return to the status screen without starting the pump.



RUNNING ●

Replace syringe in
XX:XXhh:mm

Rate

Base X.XX mL/h

SCREEN OFF

MENU

8. Troubleshooting

This section provides guidance for situations that may arise when you are using the system. If you could not correct the issue or if you do not understand the issue, call your healthcare provider or call VYALEV Support at (866) 4-VYALEV or (866) 489-2538.

8.1 What do I do if my syringe doesn't fit into the pump?

If the syringe does not fit into the pump, it means either the syringe plunger rod pusher has not retracted or the air is not fully removed.

If the syringe plunger rod pusher is not fully retracted, close the lid without the syringe in the pump. Then follow the instructions on the pump display, pressing the button to indicate that there is no syringe in the pump.

If the syringe does not fit into the pump with a fully retracted syringe plunger rod because there is still air in the syringe tip, re-attach the syringe to the vial adapter that is still attached to the vial. With the vial and syringe pointed upward, slowly push all air that remains and a small amount of liquid back into the vial. Then re-attach the infusion set tubing and try again.

After the air has been removed from the syringe, try to load the syringe again. Make sure that you are using the correct syringe, included in the list of qualified disposable parts for use with the system. This list can be found at devices.abbvie.com.

8.2 What if I indicate tubing is primed by accident, but I need to continue to prime?

Go to the change supplies menu option on the pump, then follow the instructions to prime the infusion set tubing.

8.3 What do I do if I need to change only my infusion set tubing and not the cannula?

The steps are similar to that for changing the whole infusion set. The difference is that you must disconnect the infusion set tubing from the cannula, since you are not replacing the cannula.

1. Stop the pump.
2. Disconnect the old infusion set tubing from the syringe and cannula.
3. Discard the old tubing.
4. Connect the new tubing to the syringe.
5. Prime the tubing (Navigate to "Change Supplies" and select option "Prime Infusion Line").
6. Wait 60 seconds and tap away drips that are leftover.
7. Connect the primed tubing to the cannula.
8. Start the pump.

Note: If the infusion set tubing and insertion device/cannula are packaged alone and you need only one of them, you can save the other for later use. If they are packaged together, throw away the one that was not used.

8.4 What if I cannot loosen the tubing from syringe when I replace the syringe?

If the tubing connector is tightened too much and/or sticky when attached to the syringe, it may be hard to remove. If it is hard to remove, hold a warm, damp cloth in your hand to help protect your fingers from the sharp edges of the connector. Then try to unscrew it. If that does not work right away, let the dampness of the cloth soak in and try again. If you are still not able to loosen the tubing from the syringe, you will need to replace your infusion set.

Note: **Do not** use a tool to loosen the tubing connector because it could damage the plastic part of the connector.

8.5 What if I am having trouble transferring VYALEV from the vial to the syringe?

The suggestions below may assist you as you follow the IFU for VYALEV and the IFU provided by the vial adapter manufacturer.

1. Make sure that the vial adapter spike is centered on the rubber stopper on the top of the solution vial before you apply a downward force.
2. Press vertically downward until the vial adapter snaps snugly into place onto the vial.

8.6 What if my fully-charged battery lasts less than 24 hours?

If a fully-charged battery no longer enables use for at least 24 hours, you likely need to replace the battery. Only use a fully charged battery, Model RRC1120-PM, provided by the VYAFUSER pump supplier.

8.7 What if I install a fully-charged battery and the pump doesn't power on?

First, confirm that the fully-charged battery is fully inserted and that the metal contacts on the battery line up with the metal contacts in the pump (refer to the Figures in the section ***Install Battery***). If the battery is inserted the right way and the pump is not powering on, remove the battery, inspect the contacts on the battery and pump. If there is a contaminant (e.g., dirt) or something else blocking contact between the battery and pump contacts, attempt to remove it. If the contacts look like they need cleaning, follow the steps described in the section ***Instructions for cleaning Battery contacts (if needed)***.

8.8 Instructions for cleaning the battery contacts (if needed).

- a. Make sure the battery is removed.
- b. Dip the cotton swab in isopropyl alcohol. Do not use any other cleaning agent.
- c. Depress the cotton swab against the inside of the container to remove most of the alcohol.
- d. Wipe back-and-forth with the swab against the contaminant on either the battery contact or pump contacts.
- e. Allow the contacts to fully dry before you insert the battery.

If the battery is properly seated and you've attempted to remove any visible contaminant and the pump is still not powering on, contact your healthcare provider.

8.9 What should I do if the pump screen is blank or does not respond to any of my button pushes?

If the pump is not working or the display screen is blank after you push buttons, replace the battery with a fully charged battery. If the pump still does not work, remove the battery and wait for 10 minutes. After 10 minutes, insert the fully charged battery. If the pump still does not work, contact your healthcare provider.

8.10 What should I do if my cannula becomes detached from my body after I have been using it?

If the cannula becomes loose or detached from the body, you will need to replace the entire infusion set, including the tubing and the cannula. Refer to the section of the instructions **Replace Infusion Set Tubing and Cannula (not Syringe)**.

8.11 What if I cannot remove the site connector from the cannula during temporary disconnect?

- a. Apply a warm, soaking wet, cloth to the site connector for at least 2 minutes. This will help to dissolve any dried VYALEV that may be in the connector.

Note: It may help to gently squeeze the washcloth and/or gently rub the site connector in a circular motion a few times. This will help the water get through the connector.

- b. Try to detach the site connector from the cannula and lay it flat on a clean paper towel. Make sure the site connector needle is showing so that you can inspect for a drop of VYALEV. Tap the site connector with your finger so that any drops break free from the needle tip.
- c. If you are not able to detach the site connector, re-soak the cloth. Reapply it to the site connector for another 2 minutes. Repeat this step as many times as needed until the site connector can be detached from the cannula.

Note: After you have disconnected the site connector, there may still be some dried VYALEV on the connector. This may make it hard to open when you try again.

- d. If you are not able to detach the site connector from the cannula after you try many times, you will need to remove and throw away the cannula and infusion set tubing (see **Replace Infusion Set Tubing and Cannula (not Syringe)**).

8.12 What should I do if the system is leaking or if the tubing is blocked?

If your tubing is leaking where it is connected to the syringe, make sure the connection is tight enough and secured. If the tubing is damaged or blocked, or if it is leaking from the tubing or cannula, replace the infusion set, including the tubing and cannula. Refer to the section of the instructions ***Replace Infusion Set Tubing and Cannula (not Syringe)***.

8.13 What should I do if my pump gets wet?

If the pump gets wet, dry it off with a towel. If you drop the pump by accident and it is under water, call your healthcare provider.

8.14 What should I do if I spill VYALEV?

If you spill VYALEV on a table or on your skin, use a damp cloth and wipe it off. If you spill it on your clothing, you can blot it dry or let it dry on its own. You can also remove the clothing and wash it using water and laundry detergent.

8.15 What if I need to stop using the pump for a long period of time?





If you want to stop using the pump and want to power it off completely, stop the pump, remove the battery, and replace the battery cover.

THIS PAGE IS INTENTIONALLY LEFT BLANK.

9. Alarms and Informational Messages

9.1 Alarm Overview

This section introduces the alarms and informational messages that may show on the pump display. This section also gives the actions that you need to do to correct the issue. In all cases, if you are not able to correct the issue, or if you do not understand the issue, call your healthcare provider. You can see the alarms and informational message screens are different by the icon at the top of the screen and described below.

Icon	What it indicated	Action to be taken
	High priority alarm with tones you can hear (red).	The pump may have stopped. Take action to resolve.
	Low priority alarm with tones you can hear (yellow).	The pump is running. If action is not taken as shown in the alarm message, it may lead to a high priority alarm.
	Informational message with tones you can hear.	Provides status information.
	You cannot hear the alarm for 1 minute.	Resolve the alarm by following the corrective action or acknowledge the alarm by pressing "OK".

The actions that can be taken in response to the alarms are described in the table below.

User intent	User action	System response
Mute alarm	Press any button but 'OK'.	The alarm you can hear is temporarily silenced, alarm icon remains on pump display.
Acknowledge alarm	Press 'OK'.	The alarm you can hear is silenced, alarm icon disappears from pump display. Alarm will reoccur if the problem is not fixed.
Resolve alarm	Perform corrective action as described in next section.	Alarm is resolved. System is ready to resume therapy.



The pump's alarms that you can hear will continue to sound until they are acknowledged by pressing the OK button. To temporarily mute an alarm sound, press any button other than OK. When muted, an icon will remain on the screen. If the alarm is muted and not acknowledged, the signal you can hear will resume after 1 minute. To acknowledge an alarm press OK. When acknowledged, the alarm sound will stop.

The tables on the following pages list all alarms and informational messages. The first table (9.2 High and Low Priority Alarms) contains in alphabetical order, high priority alarms (red caution symbol) and low priority alarms (yellow caution symbol).

The second table (9.3 Informational Messages) contains status information and guidance in alphabetical order. Informational messages, displayed with an "i" at the top, provide status information but are not alarms. They appear when the user tries an action that is not available (e.g., extra dose not enabled) and a notification when a pump action is completed (e.g., loading dose delivery complete).

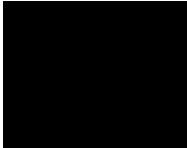
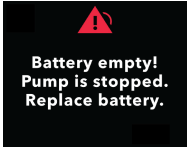
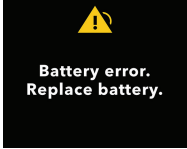
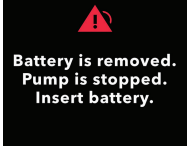

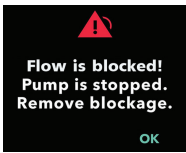
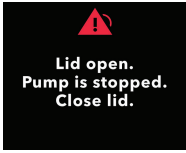
9.2 High and Low Priority Alarms (listed alphabetically)

Display	Description	Acoustic Signal	Corrective Action
	The screen remains blank and the pump does not respond to any button pushes.	None	If the pump does not respond and the display screen remains blank, replace the battery with a fully charged battery. If the pump still does not respond, remove the battery. Wait for 10 minutes. After 10 minutes, insert the fully charged battery. If the pump still does not respond, contact your healthcare provider.
	Battery is empty. Pump has stopped. Battery needs to be replaced now.	3 tones, short pause, 2 tones, repeat.	Replace the battery with fully charged battery Model RRC1120-PM, provided by the VYAFUSER pump supplier.
	Battery Error. Replace Battery.	2 tones	Replace the battery with a fully charged battery Model RRC1120-PM, provided by the VYAFUSER pump supplier.
	Battery is removed. Pump is stopped.	3 tones, short pause, 2 tones, repeat.	If the battery is in the pump, remove it, wait for a blank screen, and re-insert it. If that does not work, replace the battery.

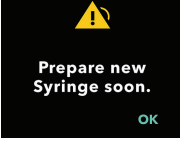
Display	Description	Acoustic Signal	Corrective Action
 <p>Flow is blocked! Pump is stopped. Remove blockage. OK</p>	<p>There is a blockage in the fluid path preventing VYALEV from being administered.</p> <p>Pump has stopped.</p>	<p>3 tones, short pause, 2 tones, repeat.</p>	<p>Remove the blockage. Inspect the tubing for kinks that could be stopping the flow of VYALEV. Open the pump lid and make sure that there is nothing in the syringe housing that is in the way of the syringe. If problem continues, replace infusion set tubing and cannula. If blockage is found in the tubing, see Troubleshooting section <i>"What do I do if I need to change only my infusion set tubing and not the Cannula?"</i></p>
 <p>Lid open. Pump is stopped. Close lid.</p>	<p>Lid has been opened.</p> <p>Pump has stopped delivering VYALEV.</p> <p>Close Lid.</p>	<p>3 tones, short pause, 2 tones, repeat.</p>	<p>Close the lid to continue receiving therapy. If the lid is closed the right way and this alarm continues, contact your healthcare provider.</p>
 <p>Low Battery. Less than 4 hours remaining. OK</p>	<p>Battery is low.</p> <p>Pump will stop within 4 hours.</p> <p>Have charged Battery ready.</p>	<p>2 tones</p>	<p>Make sure you have a fully charged battery ready.</p>

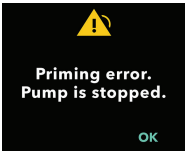
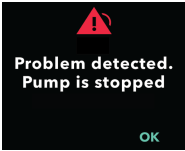
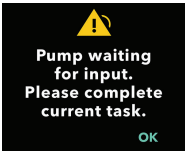
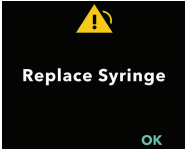
Display	Description	Acoustic Signal	Corrective Action
 <p>Low Battery. Less than 30 minutes remaining. Replace Battery soon. OK</p>	<p>Battery is low. Battery will be used up and pump will stop within 30 minutes.</p> <p>When running faster rates and when operating the pump in cold weather, the battery will be used up faster.</p> <p>Replace the battery as soon as possible.</p>	<p>3 tones, short pause, 2 tones, repeat.</p>	<p>Replace the battery with a fully charged battery or make sure you have a fully charged battery ready (see section <i>Maintenance: Replace Battery.</i>)</p>
 <p>Prepare new Syringe soon. OK</p>	<p>The syringe has been in the pump for 23 hours.</p> <p>The syringe is to be thrown away 24 hours from when the VYALEV was transferred to the syringe. Prepare a new syringe soon.</p>	<p>2 tones</p>	<p>While the therapy is still running, if refrigerated before use, remove a new solution vial from the refrigerator. Allow it to warm at room temperature for 30 minutes. Then transfer the VYALEV to the syringe as described in the <i>Instructions for Use of VYALEV.</i></p>

Display	Description	Acoustic Signal	Corrective Action
 <p>Priming error. Pump is stopped.</p> <p>OK</p>	The pump is not priming as expected and the tubing is not primed.	2 tones	<p>Inspect to see if the syringe is leaking where the tubing connects to the syringe. If it is leaking, wipe it clean, tighten the connection, and prime again.</p> <p>If there is no leak, repeat priming until the air is removed.</p>
 <p>Problem detected. Pump is stopped</p> <p>OK</p>	Pump has detected a problem and is not delivering VYALEV.	3 tones, short pause, 2 tones, repeat	<p>Press OK and follow instructions on screen to reset pump. You may need to do this more than once. If the problem persists, contact your healthcare provider. Make sure you are using a fully charged battery.</p>
 <p>Pump waiting for input. Please complete current task.</p> <p>OK</p>	<p>Pump is waiting for input.</p> <p>Please complete current task.</p>	2 tones	<p>The pump needs more input from you to continue.</p> <p>Press OK to continue with current task.</p>
 <p>Replace Syringe</p> <p>OK</p>	<p>The syringe has been in the pump for 24 hours.</p> <p>The syringe is to be thrown away after 24 hours.</p>	2 tones	<p>Replace the current syringe with a new syringe within 1 hour of first notification.</p> <p>Refer to <i>Instructions for Use of VYALEV.</i></p>

Display	Description	Acoustic Signal	Corrective Action
 <p>Syringe is empty! Pump is stopped. Replace Syringe.</p> <p>OK</p>	<p>Syringe is empty. Pump has stopped.</p> <p>Replace the current syringe with a new syringe.</p>	<p>3 tones, short pause, 2 tones, repeat</p>	<p>Replace the syringe right away with a new syringe (see section Replace Syringe).</p>
 <p>Syringe will be empty within 45 minutes.</p> <p>OK</p>	<p>At the current rate, the syringe will be empty within 45 minutes.</p>	<p>2 tones</p>	<p>While the therapy is still running, if refrigerated before use, remove a new solution vial from the refrigerator. Allow it to warm at room temperature for 30 minutes. Then transfer the VYALEV to the syringe as described in the Instructions for Use of VYALEV.</p>
 <p>Syringe will be empty within 2 hours.</p> <p>OK</p>	<p>At the current rate, the syringe will be empty within 2 hours.</p>	<p>2 tones</p>	<p>Remember to get a new syringe ready soon.</p>

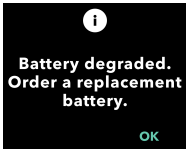
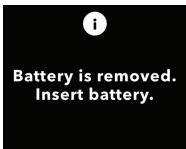
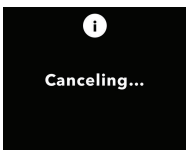
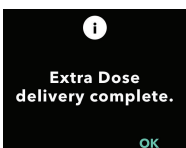
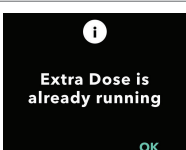
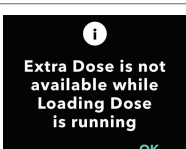

9.3 Informational Messages

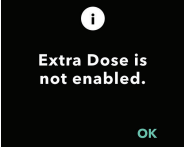
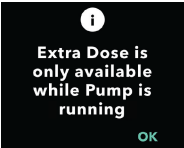
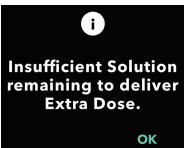
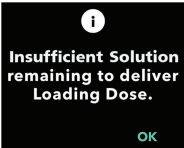
Display	Description	Acoustic Signal	Corrective Action (if applicable)
 <p>Battery degraded. Order a replacement battery. OK</p>	It is possible that the battery is not keeping a charge as expected.	2 Beeps	Replace the battery with a fully charged battery, Model RRC1120- PM, provided by the VYAFUSER pump supplier.
 <p>Battery is removed. Insert battery.</p>	Battery is removed.	2 Beeps	If the battery is in the pump, remove it, wait for blank screen, and re-insert it. If that does not work, replace the battery.
 <p>Canceling...</p>	Action has been canceled.	2 Beeps	N/A
 <p>Extra Dose delivery complete. OK</p>	Extra Dose delivery has been completed.	2 Beeps	Press OK to continue.
 <p>Extra Dose is already running OK</p>	User tries to administer an extra dose while another extra dose is being administered.	2 Beeps	Allow the extra dose to complete its administration. Press OK to continue.
 <p>Extra Dose is not available while Loading Dose is running OK</p>	Extra dose cannot be administered while loading dose is running.	2 Beeps	Wait until the loading dose has finished before administering extra dose.

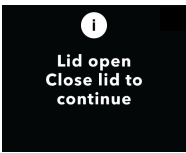
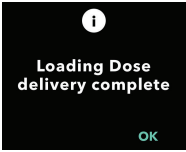
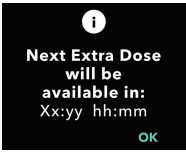
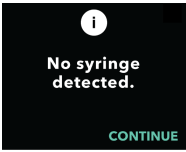
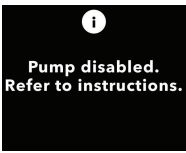
Display	Description	Acoustic Signal	Corrective Action (if applicable)
	Extra dose has not been set up on your pump.	2 Beeps	Press OK to continue.
	Extra doses can only be administered while the pump is running.	2 Beeps	Start the pump and then deliver the extra dose.
	Not enough VYALEV left in the syringe to deliver the extra dose. Syringe needs to be changed.	2 Beeps	While the therapy is still running, prepare a new replacement Syringe. If refrigerated before use, remove a new solution vial from the refrigerator. Allow it to warm at room temperature for 30 minutes. Then transfer the VYALEV to the syringe as described in the Instructions for Use of VYALEV .
	Not enough VYALEV remaining in the syringe to deliver the loading dose. Syringe needs to be changed.	2 Beeps	Change the syringe as described in Replace the Syringe .

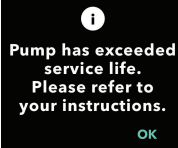
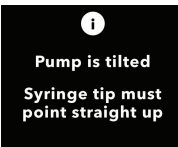
Display	Description	Acoustic Signal	Corrective Action (if applicable)
 <p>Lid open Close lid to continue</p>	The lid has been opened.	2 Beeps	Close the lid and follow the display screen prompts to acknowledge whether the syringe was inserted or removed.
 <p>Loading Dose delivery complete</p> <p>OK</p>	Loading dose delivery is complete.	2 Beeps	Press OK to continue.
 <p>Next Extra Dose will be available in: Xx:yy hh:mm</p> <p>OK</p>	Extra dose is locked out until XX hours and YY minutes from this time.	2 Beeps	Note how much time must pass until the lockout time is over and you are able to administer the next extra dose. Press OK to continue.
 <p>No syringe detected.</p> <p>CONTINUE</p>	The pump has not detected that a syringe is in the pump.	2 Beeps	If a syringe is in the pump, open the lid. Make sure the syringe is seated correctly. If there is no syringe in the pump, insert a syringe.
 <p>Pump disabled. Refer to instructions.</p>	Pump is disabled due to a pump failure. Problem cannot be resolved by replacing the battery.	2 Beeps	Contact the healthcare provider.

Display	Description	Acoustic Signal	Corrective Action (if applicable)
 <p>Pump has exceeded service life. Please refer to your instructions.</p> <p>OK</p>	<p>Pump has exceeded service life.</p> <p>Please refer to your instructions.</p>	<p>2 Beeps</p>	<p>Although the pump will continue to work, it has reached the end of its designed life. The pump should be replaced as soon as possible. Contact your healthcare provider.</p>
 <p>Pump is tilted</p> <p>Syringe tip must point straight up</p>	<p>Pump is tilted during priming.</p> <p>Point syringe straight up to continue with priming.</p>	<p>2 Beeps</p>	<p>Reposition the pump so the syringe tip point is straight up.</p>

Display	Description	Acoustic Signal	Corrective Action (if applicable)
 <p>Remove battery. Await blank screen. Re-insert battery. Refer to instructions.</p>	<p>Problem is not resolved.</p>	<p>2 Beeps</p>	<p>Remove the battery and wait until the screen goes blank. After the screen has gone blank, re-insert the battery, taking care not to press any of the pump buttons. Wait for the pump to re-start. If the problem is corrected, you must then replace the syringe with a new syringe. Otherwise the pump clock will reset "Replace Syringe in" to 24 hours and you may not receive the "Replace Syringe Alarm" when the syringe has been in the pump for 24 hours. If the problem persists, contact the healthcare provider.</p>
 <p>Syringe error. Please wait.</p>	<p>The Pump is not able to detect if a syringe is loaded or not.</p>	<p>2 Beeps</p>	<p>Wait for the pump to return to the status screen. Go to "Insert Syringe" and follow the "Change Syringe" instructions on the screen.</p>

10. Device Information

10.1 Last 3 Alarms

Note: In some cases your healthcare provider may ask you to review the most recent alarms that have appeared on your display.

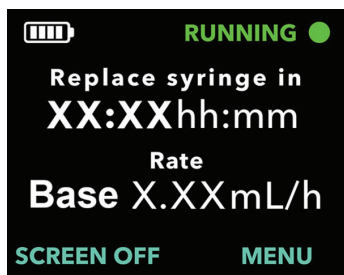

1. Turn on the pump display if needed.
 - a. Press any button (arrow keys or selection buttons).
 - b. Press MENU to display the pump menu options.

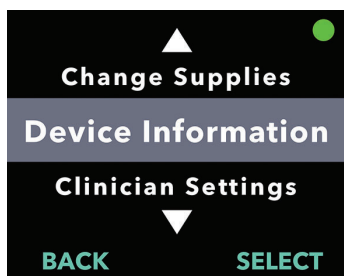

2. Use the arrow keys to scroll to and highlight the Device Information menu option.
 - a. Press *SELECT* to choose the option to view the Device Information.

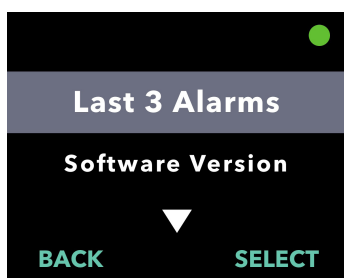

3. Use the arrow keys to highlight the *Last 3 Alarms* menu option.
 - a. Press *SELECT* to choose the option to *Last 3 Alarms* and then follow the instructions on the display.

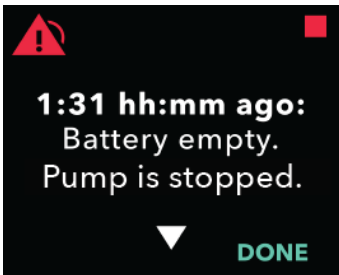

4. Review the recent alarms.

- a. The pump is able to display the last 3 high priority alarms that have occurred. Using the up and down arrows you can scroll through them.

Note: The first alarm displayed will be the most recent alarm that occurred.

Note: At 24 hours, the display will change from hh:mm (hours:minutes) to d:hh (days:hours). At 10 days, the display will change to ddd (days) ago.

Note: The pump run status in the upper right corner shows if the pump is running when this screen is displayed. When the actual high priority alarm is issued, the pump will not be running.

10.2 Software Version

Displays the version of software on the pump.

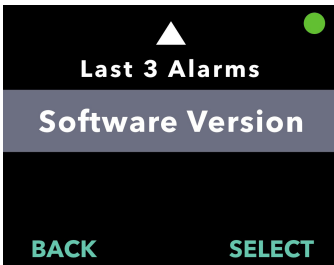

1. Use the arrow keys to highlight the **Software Version** menu option.
 - a. Press SELECT.



11. Maintenance

11.1 Replace Battery

Note: Always stop delivery of VYALEV before you replace the battery.

Note: Replace your battery with a fully charged battery every day at the same time. Make this part of your daily routine. Always charge the used battery right after removing it from the pump. This will ensure that you have a fully charged spare battery available at all times. Only use a fully charged battery, Model RRC1120-PM, provided by the VYAFUSER pump supplier.

Note: Always charge batteries fully before storing. If you do not, this could affect how the battery and the charger operate.

Note: If your fully charged battery does not last as long as you expect, see **Troubleshooting: What if my fully charged battery lasts less than 24 hours?**

Note: If the syringe has been removed during the battery replacement or the pump does not detect the syringe after the battery is replaced, the pump screen will display the “Insert Syringe” menu option rather than “Start Pump.” If this occurs, you must replace the syringe with a new syringe.

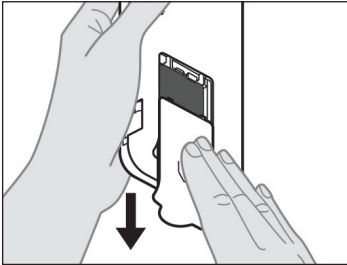

Figure BE

1. Stop the pump.
2. Remove the battery cover from the pump (see Figure BE).

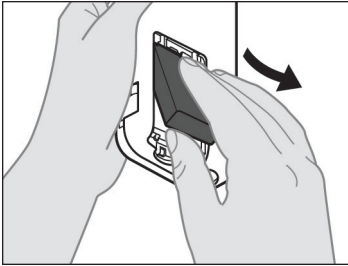

Figure BF

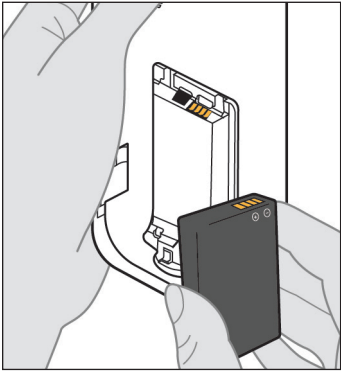

Figure BG

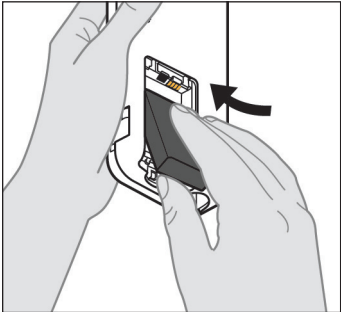

Figure BH

3. Remove the used battery (see Figure BF).

4. Insert the battery into the battery compartment.

Note: Use only a fully charged battery, Model RRC1120-PM, provided by the VYAFUSER pump supplier.

- a. Match the metal contacts of the battery and battery compartment (see Figure BG).
- b. With the metal contact end inserted first, slide the battery into the compartment (see Figure BH).

Note: You will hear a “click” when the battery is in place.

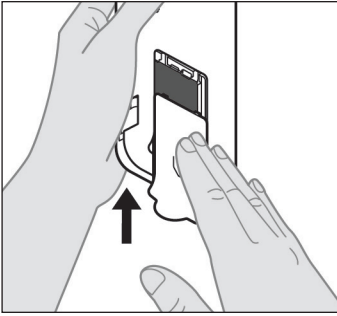

Figure B1

- Slide the battery cover onto the pump (see *Figure B1*).



Battery Charger

- Insert the used battery into the battery charger to begin the charging process.

Please refer to your **Battery Charger Instructions For Use** for detailed steps.

**Preparing for use.
Please wait...**

- After inserting the new battery, the pump will run power on self-tests.

Please wait.



- After inserting the battery, wash your hands with soap and water and dry them.

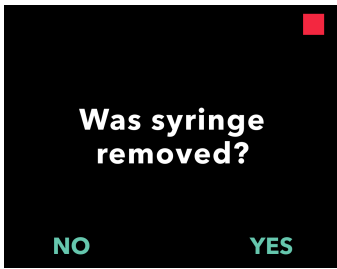

9. Confirm if the syringe was removed when you replaced the battery.

- a. Press NO if the syringe was not removed when you replaced the battery.

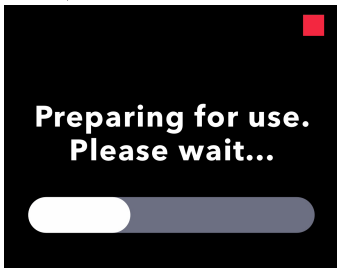

- b. Wait to allow the pump to prepare the syringe for use.

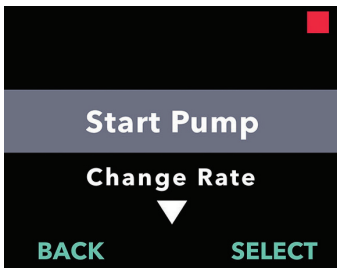

10. Choose the Start Pump menu option.

- a. Press SELECT.

11.2 Cleaning the Pump, Mains Adapter and Charger

You should clean the outside, non-electrical surfaces of the pump, mains adapter or charger, as needed. Use a soft cloth that is lightly dampened. Only use clean water and mild detergent or diluted household bleach (1 part bleach to 9 parts water). Gently wipe the outside surfaces of these parts as needed (including those of the pump that are exposed when the lid is open).

Note: If you are cleaning the mains adapter or charger, ensure the mains adapter is unplugged.

Note: Keep the battery door closed while cleaning.

Note: Allow parts to dry completely before use. You may dry them with a soft cotton cloth.

Note: Avoid spillage of liquids onto, or into, the pump. If the pump gets wet, try to dry it with clean absorbent paper towels right away.

12. Storage and Transport Conditions

The pump, battery charging system, and carrying accessory are made to operate as they are supposed to after exposure (e.g., when in storage) to each of the following conditions:

- -4 °F to 41 °F (-20 °C to 5 °C) with uncontrolled humidity
- 41 °F to 104 °F (5 °C to 40 °C), up to 90% relative humidity non-condensing
- 104 °F to 140 °F (40 °C to 60 °C), up to 15% relative humidity non-condensing
- Atmospheric pressures ranging from 53.3 kPa to 106 kPa.

The system is made to operate between 41 °F (5 °C) and 104 °F (40 °C). If stored at temperatures below 41 °F (5 °C) or above 104 °F (40 °C), do not use the system right away. Let the system sit at room temperature, 68 °F (20 °C), for at least 30 minutes before you use it.

For questions or problems, call your healthcare provider, or call VYALEV Support at (866) 4-VYALEV or (866) 489-2538.

THIS PAGE IS INTENTIONALLY LEFT BLANK.

13. Technical Specifications

13.1 Technical Features

Pump Dimensions	170 x 76 x 33 mm (6.7 x 3.0 x 1.3 in)
Pump Weight	285 g (10.0 oz.), including battery
Battery	3.6 V Li-Ion / 2.35 Ah / 8.46 Wh
Pump Ingress Protection Rating	IP22
Pump Security Lock Levels	Protected Clinician Mode
Permissible Positions (Orientations) of the Pump	No specific position (orientation) required
Continuous Dose Delivery Flow Rates	Programmable from 0.15 mL/hr to 1.25 mL/hr with 0.01 mL/hr increments
Number of Selectable Flow Rates	Up to 3, based on configuration
Average Flow Rate During Extra Dose and Loading Dose Delivery	5.5 mL/hr
Priming Volume	From 0.15 mL to 0.6 mL
Extra Dose Volume	Programmable from 0.1 mL to 0.3 mL in 0.05 mL increments
Lock-out Time Interval Between Extra Doses	Programmable from 1 hour to 24 hours in 15-minute increments
Loading Dose Volume	Programmable from 0.1 mL to 3.0 mL in 0.1 mL increments
Lock-out Time Interval Between Loading Doses	Programmable from 3 hours to 8 hours in 1-hour increments
Typical Service Life of the Pump	The pump is expected to have a service life of 3 years.
Time to Bring System to Operating Temperature	<p>The system is made to operate at between 41 °F (5 °C) and 104 °F (40 °C). It may, however, be stored between -4 °F (-20°C) and 140 °F (60 °C).</p> <p>If stored at temperatures below 41 °F (5 °C) or above 104 °F (40 °C), do not use the system right away. Let the system sit at room temperature, 68 °F (20 °C), for at least 30 minutes before you use it.</p>

Maximum Infusion Pressure Generated by Pump	200 kPa
Maximum Time for Activation of the Occlusion Alarm	<p>Note: Changes in temperature and infusion set length may affect the time to detect an occlusion (blockage or closure).</p> <p>It will take 5 hours or less to detect an occlusion when infusing under the following conditions:</p> <ul style="list-style-type: none"> • basal delivery flow rate of 0.15 mL/hr • infusion set length of 23.62 inches (60 cm) • occlusion introduced at patient end of infusion set • ambient temperature of 68 +/- 4 °F (20 +/- 2 °C) • ambient humidity of 65 +/- 5 % RH <p>It will take 2 hours or less to detect an occlusion when infusing under the following conditions:</p> <ul style="list-style-type: none"> • basal delivery flow rate of 0.70 mL/hr • infusion set length of 23.62 inches (60 cm) • occlusion introduced at patient end of infusion set • ambient temperature of 68 +/- 4 °F (20 +/- 2 °C) • ambient humidity of 65 +/- 5 % RH
Maximum Volume of Unintended Bolus After Occlusion	<p>The pump, when pumping at 0.7 mL/hr, has a maximum unintended bolus volume of 0.8 mL under the following conditions:</p> <ul style="list-style-type: none"> • infusion set length of 23.62 inches (60 cm) • occlusion introduced at patient end of infusion set • ambient temperature of 68 +/- 4 °F (20 +/- 2 °C)
System Operating Conditions	<p>The pump is made to perform as it is supposed to when it operates within the correct temperature, humidity, and atmospheric pressure ranges. The temperature range should be between + 41 °F (5 °C) and to + 104 °F (40 °C), inclusive. The humidity range should be from 15% to 90% non-condensing. The atmospheric pressure range should be from 70 kPa to 106 kPa.</p>
Operating Height of the Pump Relative to the Infusion Site	<p>The pump is made to keep delivery accuracy when it is in the correct placement. The pump should be within 7 3/4 inches (20 cm) above and 21 1/2 inches (55 cm) below the infusion site. Placing it higher or lower than this could impact delivery accuracy.</p>
Pump Kit Storage and Transport Conditions (including the Pump, Battery Charging System, and Carrying Accessory)	<p>-4 °F to 41 °F (-20 °C to 5 °C) with uncontrolled humidity 41 °F to 104 °F (5 °C to 40 °C), up to 90% relative humidity non-condensing</p> <p>104 °F to 140 °F (40 °C to 60 °C), up to 15% relative humidity non-condensing</p> <p><i>Note:</i> At atmospheric pressure ranging from 53.3 kPa to 106 kPa.</p>

<p>Delivery Accuracy</p>	<ul style="list-style-type: none"> • Valid for environmental operating conditions specified above • Valid for infusion sets listed at devices.abbvie.com <p>Continuous Doses:</p> <ul style="list-style-type: none"> • $\pm 10\%$ for continuous dose flow rates <p>Loading Doses:</p> <ul style="list-style-type: none"> • $\pm 25\%$ for delivery volumes up to but not including 1.4 mL • $\pm 10\%$ for delivery volumes equal to or greater than 1.4 mL <p>Extra Doses:</p> <ul style="list-style-type: none"> • $\pm 25\%$
<p>Maximum Pumping Rate During Priming</p>	<p>The maximum flow rate for the first priming step is 90 mL/hr. The priming volume is limited to 0.6 mL per priming cycle.</p>
<p>Typical Pump Operating Time with a New Fully-Charged Battery</p>	<p>A new, fully-charged battery will power the pump, even at the highest basal delivery rate, for at least 37 hours.</p>

* For delivery periods of 6 hours or more, the average flow rate will be within $\pm 10\%$ of the programmed rate across the entire programmable range. For delivery periods of 1 hour, the average flow rate may differ from the programmed rate by up to ± 0.1 mL/hr for flow rates from 0.15 mL/hr to 0.70 mL/hr. This is because VYAFUSER is a pulsatile pump, and each pulse-shot delivers a small, discrete volume of drug product at regular time intervals. The frequency of these pulse-shots is determined by the programmed flow rate. Thus, at low to intermediate flow rates (0.70 mL/hr and under), flow rate sample periods of 1 hour will not necessarily contain the same number of pulse-shots.

The pump has the following main ways to reduce under-infusion:

- Required confirmation of all delivery rates and volumes set by the healthcare provider.
- Required confirmation of all delivery rates selected by the user.
- Occlusion detection
- Circuitry that checks for software or hardware that is not working correctly.

The pump has the following main ways to reduce over-infusion:

- Maximum programmable rates are consistent with expected patient needs.
- Required confirmation of all delivery rates and volumes set by the healthcare provider.
- Required confirmation of all delivery rates selected by the user.
- Circuitry that checks for software or hardware that is not working correctly.

Note: Maximum volume infused under single fault conditions:

If the pump malfunctions in an over-infusion condition at a delivery rate of less than 6.5 mL/hr, the safety circuit will not detect the over-infusion. During this condition, the entire syringe volume (up to 11 mL) would be delivered at that rate.

Description of pump occlusion threshold:

- Prevention of the pressure in the syringe exceeding 200 kPa.
- Detecting syringe pressure increase if line is occluded at pressures below 200 kPa.

Sound Pressure Level:

The high priority alarm has a sound pressure level range from 50 dBA to 67 dBA at 1 meter. The low priority alarm has a sound pressure level range from 49 dBA to 62 dBA at 1 meter.

Continuous Dose Delivery Accuracy:

Continuous dose delivery accuracy testing was performed based upon IEC 60601-2-24:2012. Testing was performed with distilled water at room temperature with a 9-mm needle, 60-cm long Neria Guard infusion set and with a programmed rate of 0.70 mL/hr: results are shown below.

Mean flow error: -0.14%

Start-up graph

Flow rate

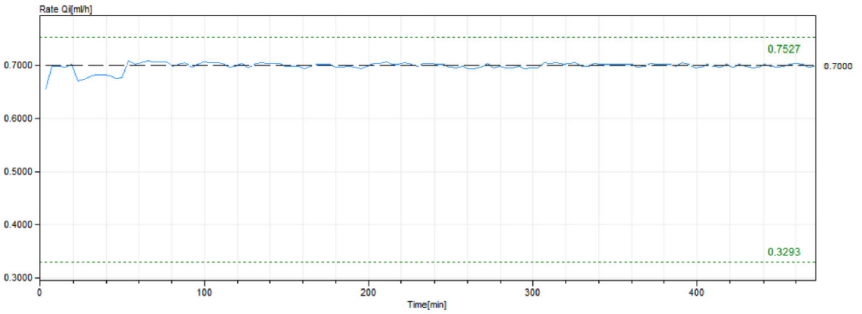

Trumpet curve from minute 472 - 856

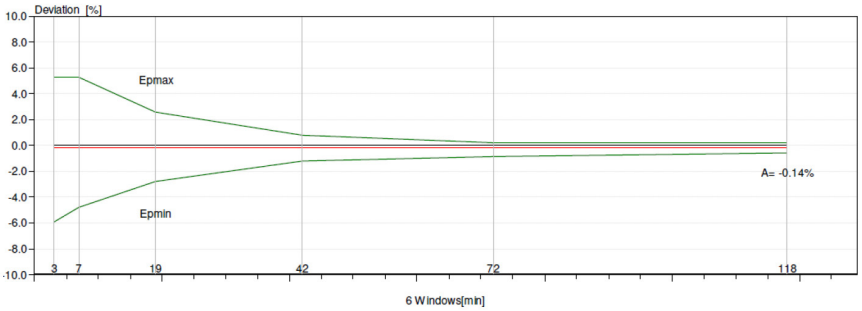

Bolus Delivery Accuracy:

Bolus delivery accuracy data were generated based upon IEC 60601-2-24:2012. Testing was performed with distilled water at room temperature with a 9-mm needle, 60-cm long Neria Guard infusion set.

Bolus Dose Volume Target	Number of Successive Bolus Deliveries	Delivered Volume (mL)	Calculated Mean Deviation from Set Value (mL)	Calculated Percentage Deviation from the Set Value (%)
0.1 mL (Minimum bolus volume setting)	25	2.52755	0.02755	Total volume: 1.1 Max negative: 5.65 Max positive: 4.25
3.0 mL (Maximum bolus volume setting)	3	9.23863	0.23863	Total volume: 2.65 Max negative: 4.23 Max positive: 6.39

Delivery Accuracy Under High Backpressure:

Delivery accuracy data were generated under simulated high back-pressure conditions (such as from partial occlusions) and using the time to detect as the test window. This effectively characterizes the mean flow rate error that could occur under these conditions both including the initial 30-60 min start-up period, and within the steady-state period to which the system subsequently converges.

Delivery Accuracy Under High Backpressure		
Target Flow Rate	Mean Flow Rate Error (Including Start-Up)	Mean Flow Rate Error (Steady-State)
3.0 mL bolus	-4.84%	--
1.25 mL/hr	-10.28%	-0.68%
0.70 mL/hr	-8.84%	-0.94%
0.15 mL/hr	-16.08%	-4.48%

13.2 Battery Service Life

A battery is expected to last for 2 years under typical use conditions. If a fully-charged battery no longer enables use for at least 24 hours, you likely need a replacement battery.

13.3 MRI Safety Information

The VYAFUSER pump is magnetic resonance (MR) unsafe.

There is a risk that the pump will go into fast motion (projectile) in MR environments.

13.4 Electromagnetic Compatibility

The electromagnetic compatibility tests were done to comply with the standards:

- IEC 60601-2-24:2012, Medical electrical equipment, Part 2: Particular requirements for the safety of infusion Pumps and controllers;
- IEC 60601-1-2 Ed. 4:2014, Medical electrical equipment, Part 1: General requirements for basic safety and essential performance – collateral standard: Electromagnetic compatibility – Requirements and tests.
- RTCA/DO-160G: Environmental Conditions and Test Procedures for Airborne Equipment: Section 20.5, Radiated Susceptibility Test, Category T (100 MHz – 8 GHz, 5 V/m)
- AIM 7351731:2017: Medical Electrical Equipment and System Electromagnetic Immunity test for Exposure to Radio Frequency Identification Readers

Guidance and Manufacturer's Declaration – Electromagnetic Emissions		
The correct way to use the pump with battery is in the electromagnetic environment noted below. Make sure they are used in this environment.		
Emissions Test	Compliance	Electromagnetic Environment – Guidance
RF emissions: CISPR 11	Group 1	The battery-powered pump does not send any wireless data, so it's not likely to interfere with nearby electronic devices.
RF emissions CISPR 11	Class B	The pump with battery is made for use in all places including homes and apartments.
Harmonic emissions IEC 61000-3-2	Not Applicable	
Voltage fluctuations/ flicker emissions IEC 61000-3-3	Not Applicable	

Guidance and Manufacturer's Declaration – Electromagnetic Immunity

The correct way to use the pump with battery is in the electromagnetic environment noted below. Make sure they are used in this environment.

Immunity Test	IEC 60601 Test Level	Compliance Level	Electromagnetic Environment – Guidance
Electrostatic discharge (ESD) IEC 61000-4-2	± 8 kV contact ± 2, 4, 8, 15 kV air	± 8 kV contact ± 2, 4, 8, 15 kV air	Floors should be wood, concrete, or ceramic tile. If floors are covered with man-made (synthetic) material, the relative humidity should be at least 30%. The pump may reset at 15 kV, but it is ensured that the pump is safe by completing POST sequence.
Surge IEC 61000-4-5	± 1 kV line(s) to line(s) ± 2 kV line(s) to earth	Not Applicable Not Applicable	Not Applicable, the pump can only be powered from a battery. Not Applicable, the pump can only be powered from a battery.
Voltage dips, short interruptions and voltage variations on power supply input lines IEC 61000-4-11	0 % UT ; 0.5 cycle At 0°, 45°, 90°, 135°, 180°, 225°, 270°, and 315°	Not Applicable	Not Applicable, the pump can only be powered from a battery.
Power frequency (50/60 Hz) magnetic field IEC 61000-4-8	30 A/m, 50 Hz or 60 Hz	100 A/m, 50/60 Hz	If the image is distorted, the magnetic field may be too much. You may need to place the pump with battery further from sources of power frequency magnetic fields. You could also install magnetic shielding. The power frequency magnetic field should be measured where you want to install to make sure that it is low enough.
Electrical fast transient/burst IEC 61000-4-4	± 2 kV, 100kHz repetition frequency	Not Applicable	Not Applicable, the pump can only be powered from a battery.

Immunity Test	IEC 60601 Test Level	Compliance Level	Electromagnetic Environment – Guidance
Conducted RF IEC 61000-4-6	3 Vrms on 150 kHz to 80 MHz 1 kHz 80% AM modulation 6 Vrms in ISM bands	3 Vrms on 150 kHz to 80 MHz 1 kHz 80% AM modulation 6 Vrms in ISM bands	Refer to table “Test levels for Proximity fields from RF wireless communications equipment” related to immunity of the pump from portable and mobile RF communications equipment.
Radiated RF IEC61000-4-3	10 V/m 80 MHz – 2.7 GHz 80 % AM at 1 kHz	10V/m	

AIM 7351731:2017 RFID IMMUNITY

Standard	Description	AIM 7351731:2017 Compliance Level	AIM 7351731:2017 Test Level
ISO 14223	Magnetic Immunity	134.2 kHz, 65 A/m	134.2 kHz, 65 A/m
IEC 14443-3 TYPE A	Magnetic Immunity	13.56 MHz, 7.5 A/m	13.56 MHz, 7.5 A/m
IEC 14443-3 TYPE B	Magnetic Immunity	13.56 MHz, 7.5 A/m	13.56 MHz, 7.5 A/m
IEC 15693/ISO 18000-3 MODE 1	Magnetic Immunity	13.56 MHz, 5 A/m	13.56 MHz, 5 A/m
IEC 15693/ISO 18000-3 MODE 3	Magnetic Immunity	13.56 MHz, 12 A/m	13.56 MHz, 12 A/m
IEC 18000-7	RF Immunity	433 MHz, 3 V/m	433 MHz, 3 V/m
IEC 18000-63 TYPE C	RF Immunity	860-960 MHz, 54 V/m	860-960 MHz, 54 V/m
IEC 18000-4 MODE 1	RF Immunity	2.54 GHz, 54 V/m	2.54 GHz, 54 V/m

Immunity to proximity fields from RF wireless communications equipment:

As per the use environment, the pump can come close to other RF wireless communication equipment like mobile phones. The test levels were increased considering the minimum distance of 3.1 inches (8 cm) using the below equation.

$$E = (6/d) * \sqrt{P}$$















Where P is the maximum power in W, d is the minimum separation distance in m, and E is the immunity test level in V/m.







Test levels for Proximity fields from RF wireless communications equipment						
Test Frequency MHz	Band MHz	Service	Modulation	Maximum Power (W)	Distance (m)	Compliance test level (V/m)
385	380-390	TETRA 400	Pulse modulation 18 Hz	1.8	0.08	101
450	430-470	GMRS 460, FRS 460	FM ± 5 kHz deviation 1 kHz sine wave	2	0.08	106
710	704-787	LTE Band 13, 17	Pulse modulation 217 Hz	0.2	0.08	34
745						
780						
810	800-960	GSM 800/900, TETRA 800, iDEN 820, CDMA 850, LTE Band 5	Pulse modulation 18 Hz	2	0.08	106
870						
930						
1720	1700-1990	GSM 1800; CDMA 1900; GSM 1900; DECT; LTE Band 1, 3, 4, 25; UMTS	Pulse modulation 217 Hz	2	0.08	106
1845						
1970						
2450	2400-2570	Bluetooth, WLAN, 802.11 b/g/n, RFID 2450, LTE Band 7	Pulse modulation 217 Hz	2	0.08	106
5240	5100-5800	WLAN 802.11 a/n	Pulse modulation 217 Hz	0.2	0.08	34
5500						
5785						
<p>The test frequency step was 5 MHz (e.g., 704-787 MHz range was measured from 705-785 MHz using 5 MHz steps).</p> <p>As an alternative to FM modulation, 50% pulse modulation at 18 Hz was chosen at 450 MHz test frequency.</p> <p>Additional test was performed at 3.5 GHz (WiMAX) and test level of 106 V/m (considering 0.08 m separation distance).</p>						

THIS PAGE IS INTENTIONALLY LEFT BLANK.

14. Reference

14.1 Explanation of Symbols

Symbol	Title and Designation Number of Standard, Regulation or Guidance	Reference Number	Title/Meaning of Symbol
	ISO 7010:2019	ISO 7010-W001	General Warning Sign
	ANSI/AAMI/ISO 15223-1:2021	5.1.1	Manufacturer
	ANSI/AAMI/ISO 15223-1:2021	5.1.3	Date of Manufacture
	ANSI/AAMI/ISO 15223-1:2021	5.1.4	Use-by-date (expiration date)
	ANSI/AAMI/ISO 15223-1:2021	5.7.7	Medical Device
	ANSI/AAMI/ISO 15223-1:2021	5.1.5	Batch Code
	ANSI/AAMI/ISO 15223-1:2021	5.1.6	Catalog Number
	ANSI/AAMI/ISO 15223-1:2021	5.1.7	Serial Number
	ANSI/AAMI/ISO 15223-1:2021	5.3.4	Keep Dry
	ANSI/AAMI/ISO 15223-1:2021	5.3.7	Temperature Limits
	ANSI/AAMI/ISO 15223-1:2021	5.3.8	Humidity Limitation
	ANSI/AAMI/ISO 15223-1:2021	5.3.9	Atmospheric Pressure Limitation
	1. ASTM F2503-20 2. Testing and Labeling Medical Devices for Safety in the Magnetic Resonance (MR) Environment, FDA Guideline May 20, 2021	1. Figure 9 2. VIII	MR Unsafe The device is magnetic resonance unsafe. Keep the device away from places with magnetic resonance, such as MRI scanner rooms.
	EN 50419:2006	Clause 4.2	Throw away (dispose of) this product in line with local regulations

Symbol	Title and Designation Number of Standard, Regulation or Guideline	Reference Number	Title/Meaning of Symbol
GTIN	N/A	N/A	Global Trade Identification Number
	EU Directive 94/62/EC of 20 December 1994 on Packaging and Packaging Waste & EU Commission Decision 97/129/EC	20 is reserved for corrugated fiberboard (PAP-paper)	Recycling
	IATA Dangerous Goods Regulations	Figure 7.1.C	Dangerous Goods
	ISO 7010:2019	ISO 7010- M002	Refer to instruction manual/ booklet
	IEC 60417:2002 DB	IEC 60417- 5333	Type BF Applied Part
IP22	IEC 60529:2001	Clause 4.1 and 4.2	Protection against foreign objects of 12.5 mm and greater in diameter Protection against water drops falling straight down when enclosure tilted up to a 15° angle
Rx only	21CFR801.109	(b) (1)	This symbol means that an order from a healthcare provider is needed to use or sell the drug or device
	ANSI/AAMI/ISO 15223-1:2021	5.2.3	Sterilized using ethylene oxide Applies to sterile disposable parts
	ANSI/AAMI/ISO 15223-1:2021	5.2.4	Sterilized using irradiation Applies to sterile disposable parts

References

ISO 15223-1:2021 Medical Devices — Symbols to be used with medical device labels, labeling, and information to be supplied — Part 1: General Requirements

ISO 7010:2019 Graphical symbols — Safety colours and safety signs — Registered safety signs

IEC 60529:2001 Degrees of protection provided by enclosure (IP code)







IEC 60417:2002 DB Graphical symbols for use on equipment

Testing and Labeling Medical Devices for Safety in the Magnetic Resonance (MR) Environment, FDA Guideline May 20, 2021

21 CFR 801.109 Code of Federal Regulations Title 21 Volume 8 Sec.801.109 Prescription Devices

ASTM F2503-20 Standard Practice for Marking Medical Devices and Other Items for Safety in the Magnetic Resonance Environment

14.2 Pump Kit Labels

Symbol	Title and Designation Number of Standard, Regulation or Guideline	Reference Number	Title/Meaning of Symbol
	N/A	N/A	Instruction Manual
	N/A	N/A	Charging System (mains adapter and charging station)
	N/A	N/A	Charging System Note: Lift up and to the left to open
	N/A	N/A	Battery
	N/A	N/A	Pump
	N/A	N/A	Carrying Accessory
	N/A	N/A	Carrying Accessory Note: Lift up and to the right to open

14.3 Tubing, Adapters, and Accessories

The disposable parts that have been qualified for use with this system can be found at: devices.abbvie.com. This includes the vial adapter, infusion set (inserter, cannula and tubing), and syringe.

This Instructions for Use has been approved by the U.S. Food and Drug Administration.

Approved: 10/2024